

INTEX®

2014 COMFORT REST™



2014 COMFORT COLLECTION

Comfort Rest™



Intex Development Co. Ltd., Hong Kong



Intex Recreation Corp, Long Beach, CA, USA



Intex Trading B.V., The Netherlands



Unitex Service (France) S.A.S., France



Intex Administration Building Landscape, Xiamen, China



Intex Manufacturing and Distribution Complex, Xiamen, China

INTRODUCTION

The Intex Family of companies is dedicated to developing and manufacturing the highest quality products that not only provide the best value in price, but are innovative, fun and exciting. Backed by excellent Customer Service, Intex also provides first-rate after sales support. The 100+ independently owned and locally operated companies that make up the Intex Family, all embrace this commitment to quality, service and price and are committed to working together to ensure the satisfaction of the families and individuals across the globe who enjoy these products. This has become the hallmark of Intex around the world.

As a true industry leader, Intex boasts state of the art factories, trained and motivated people, products that meet rigorous testing requirements, and a Customer Service organization that will go extra lengths to ensure our customers are satisfied and happy with their purchases.

That's why when you purchase an Intex product you can be confident that you are buying the best product, at the best price, backed by the best Customer Service organization in the industry.

2014

Intex is committed to delivering top quality products at a great value with the backing of a responsive Customer Service organization. Our Airbed line is unmatched for breadth and beauty. Our Comfort Rest™ line consists of three series designed to meet all of your customers' needs: the "Outdoor" series is engineered for camping, travel, and all-around rugged use. It features stain-resistant materials, with beds perfectly suited to the outdoor environment. The "Inhome" series offers a wide selection of standard height and luxurious raised beds in a range of colors, sizes, and accessories to fit all decors and budgets. And for the young at heart, our "Air Furniture" series comes with bright colors and fresh design concepts, guaranteed to attract a loyal following of young adults! Ask your Intex representative for any of our product catalogs – we are confident that you will agree that Intex's product line is unmatched in meeting your needs.



100% of our airbeds are quality tested to be air tight before they leave our factory.

2014



06 Dura-Beam™
20 Outdoor
28 Inhome
60 Air Furniture
80 Accessories



100% of our airbeds are quality tested to be air tight before they leave our factory.

INTRODUCING

DURA-BEAM™ TECHNOLOGY

by INTEX®

CONTOURED SUPPORT SYSTEM

Our new innovative, patent pending Dura-Beam™ Technology airbeds are comprised of thousands of high-strength polyester fibers. Unlike traditional airbed construction, these high-strength polyester fibers do not stretch over time, resulting in amazing durability for years of lasting comfort. Dura-Beam™ interior construction provides the ideal firmness for superb support and rejuvenating sleep.



Designed for Comfort
Engineered for Durability



DURA-BEAM™ TECHNOLOGY

Standard interior construction has been enhanced with lightweight, high-strength fibers for amazing durability and comfort!

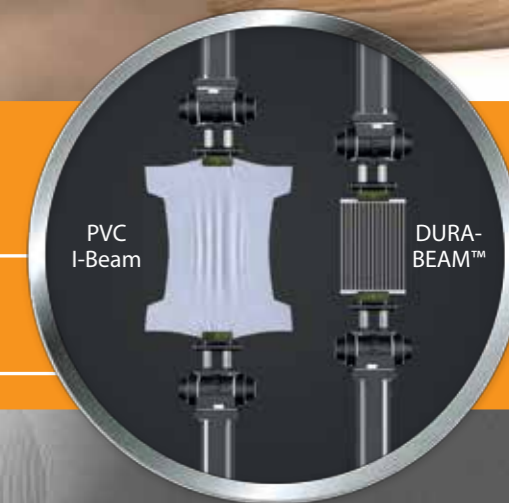

100% of our airbeds are quality tested to be air tight before they leave our factory.

ROLL 'N GO™ BED

WITH DURA-BEAM™ CONSTRUCTION

This PVC Free airbed is constructed of laminated TPE, which means it is:

- Super Tough – Softens up the rough outdoors with a very durable, eco-friendly material
- Strong Support System – Inflates up to three times the pressure of a regular PVC junior-twin airbed for a firmer sleeping surface
- Ultra Lightweight – Weighs approximately one fourth less than a common junior-twin PVC constructed airbed

AIRBED WITH HAND PUMP

Item	Size	Approximate Inflated Size	Hand Pump	Case Pack	Case Weight
68711 / E	JR.Twin	30" x 75" x 6" (76cm x 191cm x 15cm)	68612	4 Ea.	23.0 lb. (10.5kg)

new!

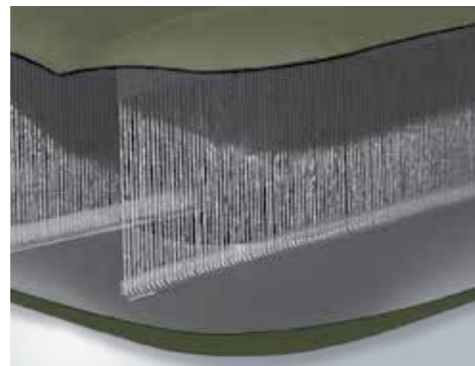

Patent pending
Dura-Beam™ Construction



Made with ultra lightweight
phthalate-free material

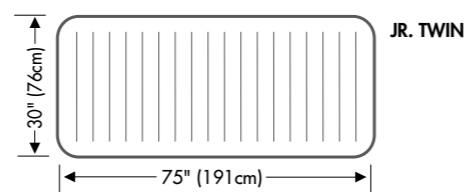

Portable and Compact

For the true outdoor camper, Intex is proud to introduce an improved, ultra lightweight, eco-friendly Airbed.

This PVC-free laminated bed is built with our new, patent-pending Dura-Beam™ construction. Combined with an extra-strong, lightweight TPE outer surface, this Bed is ultra strong, ultra light, and ultra convenient. Perfect for the Great Outdoors! For extra convenience, the Roll 'N Go™ Bed comes with a hand-held manual air pump.

Ultimate Outdoor Bed with Inflating Pump

- Quality tested 14.4 gauge (0.36mm) specs
- Eco-friendly TPE laminated fabric – phthalate-free material
- Dura-Beam™ interior construction
- Hand-held hi-output lightweight manual air pump
- Folds compactly for storage
- Duffel bag with handle included
- Shelf box



MAXIMUM DURABILITY

The strong TPE (Thermoplastic Elastomer) laminated material and innovative Dura-Beam™ inner construction transform the toughest ground into a refreshing night's sleep.

It retains elasticity in temperature as low as -4° F/-20° C.

Made of TPE – A PVC-free
eco friendly material



SUPER-TOUGH™ AIRBED

WITH DURA-BEAM™ CONSTRUCTION

AIRBED ONLY

Item	Size	Approximate Inflated Size	Case Pack	Case Weight
68725 / E	JR. Twin	30" x 75" x 6" (76cm x 191cm x 15cm)	6 Ea.	34.2 Lb. (15.6kg)

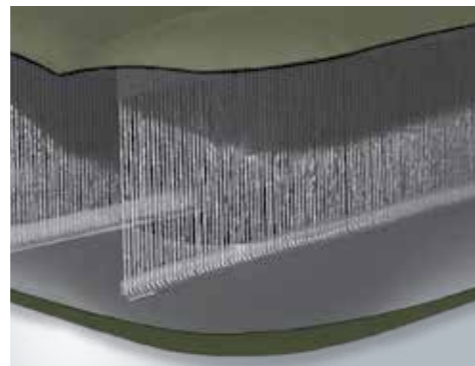

Patent pending
Dura-Beam™ Construction



Bellows foot pump
(#68726/E)



USB and 12V charger
for convenient charging
(#68727/E)



Perfect for camping with
rechargeable battery pack or
6 C-cell batteries (not included)
(#68727/E)



AIRBED WITH BELLOWS FOOT PUMP

Item	Size	Approximate Inflated Size	Case Pack	Case Weight
68726 / E	Twin	39" x 75" x 8" (99cm x 191cm x 20cm)	4 Ea.	33.5 Lb. (15.2kg)

AIRBED WITH BUILT-IN RECHARGEABLE BATTERY PUMP

Item	Size	Approximate Inflated Size	Case Pack	Case Weight
68727 / E	Twin	39" x 75" x 8" (99cm x 191cm x 20cm)	3 Ea.	28.7 Lb. (13.1kg)

Intex is proud to introduce the ultimate Airbed for campers.

Our Super-Tough™ PVC and polyester laminate create a smooth yet highly puncture resistant surface, guaranteed to give campers a great night's sleep. This Super-Tough™ laminate, coupled with our all new Dura-Beam™ construction, makes this bed, the ultimate camping airbed.

For the ultimate in convenience, the Super-Tough™ bed is also available with a built-in, rechargeable battery pump.

STRENGTH, LIGHT-WEIGHT, CONVENIENCE & COMFORT

- Quality tested 16.8 gauge (0.42mm) specs
- Super-Tough™ laminated exterior surfaces
- Dura-Beam™ interior construction
- Includes carry bag
- Folds compactly for storage
- Shelf box

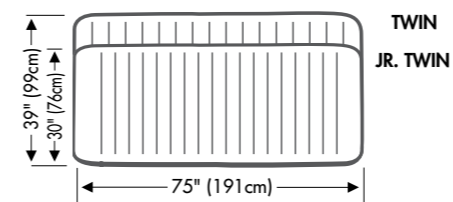

COMFORT-PLUSH MID RISE AIRBED

WITH DURA-BEAM™ CONSTRUCTION

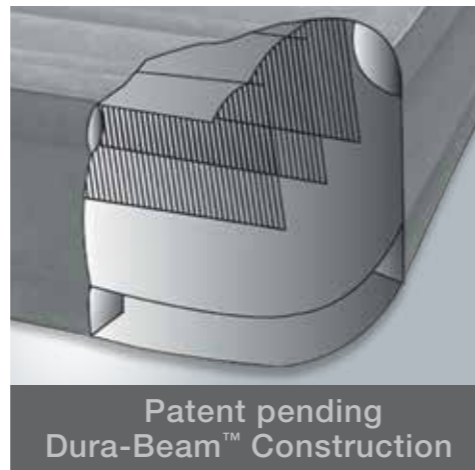

Patent pending Dura-Beam™ Construction

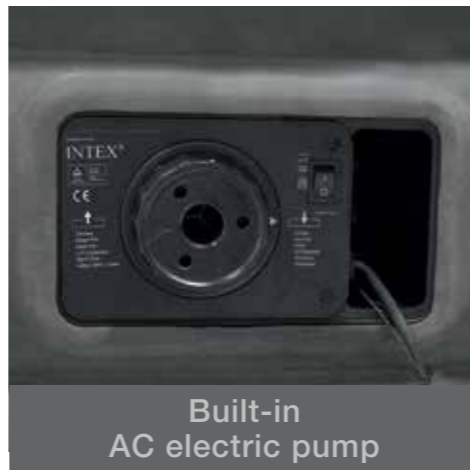

Built-in AC electric pump

INFLATING TIMES*	
AC Electric Pump	
Twin	2 minutes
Full	3 minutes
Queen	3 minutes

* Inflating time varies by mattress size and desired firmness

13" (33cm) BED HEIGHT

AIRBED WITH BUILT-IN ELECTRIC PUMP

Item	Size	Approximate Inflated Size	Built-in Pump	Case Pack	Case Weight
67765 / E 67766	Twin	39" x 75" x 13" (99cm x 191cm x 33cm)	110 - 120V 220 - 240V	3 Ea.	39.4 Lb. (17.9kg)
67767 / E 67768	Full	54" x 75" x 13" (137cm x 191cm x 33cm)	110 - 120V 220 - 240V	2 Ea.	31.7 Lb. (14.4kg)
67769 / E 67770	Queen	60" x 80" x 13" (152cm x 203cm x 33cm)	110 - 120V 220 - 240V	2 Ea.	35.8 Lb. (16.3kg)

Intex is proud to introduce a Mid-Rise Airbed for demanding consumers that's sure to delight their guests.

Our patent-pending Dura-Beam™ construction replaces traditional vinyl beams with beams comprised of thousands of high-strength spun polyester fibers. These revolutionary, eco-friendly Dura-Beam™ fibers are significantly stronger and lighter than traditional beams, and they do not stretch over time under air pressure. So they provide an amazingly comfortable and supportive sleeping surface with just the right amount of firmness.

The sleeping surface is covered in soft flocking for extra comfort, and for increased stability the entire bed is surrounded with an additional air chamber. A built-in electric pump provides further convenience.

Designed for Comfort. Engineered for Durability.

- Quality tested 21.2 gauge (0.53mm) waterproof flocked top and sides with 15 gauge (0.38mm) vinyl bottom
- Dura-Beam™ interior construction
- Built-in electric pump
- Includes hand carry bag
- Folds compactly for storage
- Shelf box

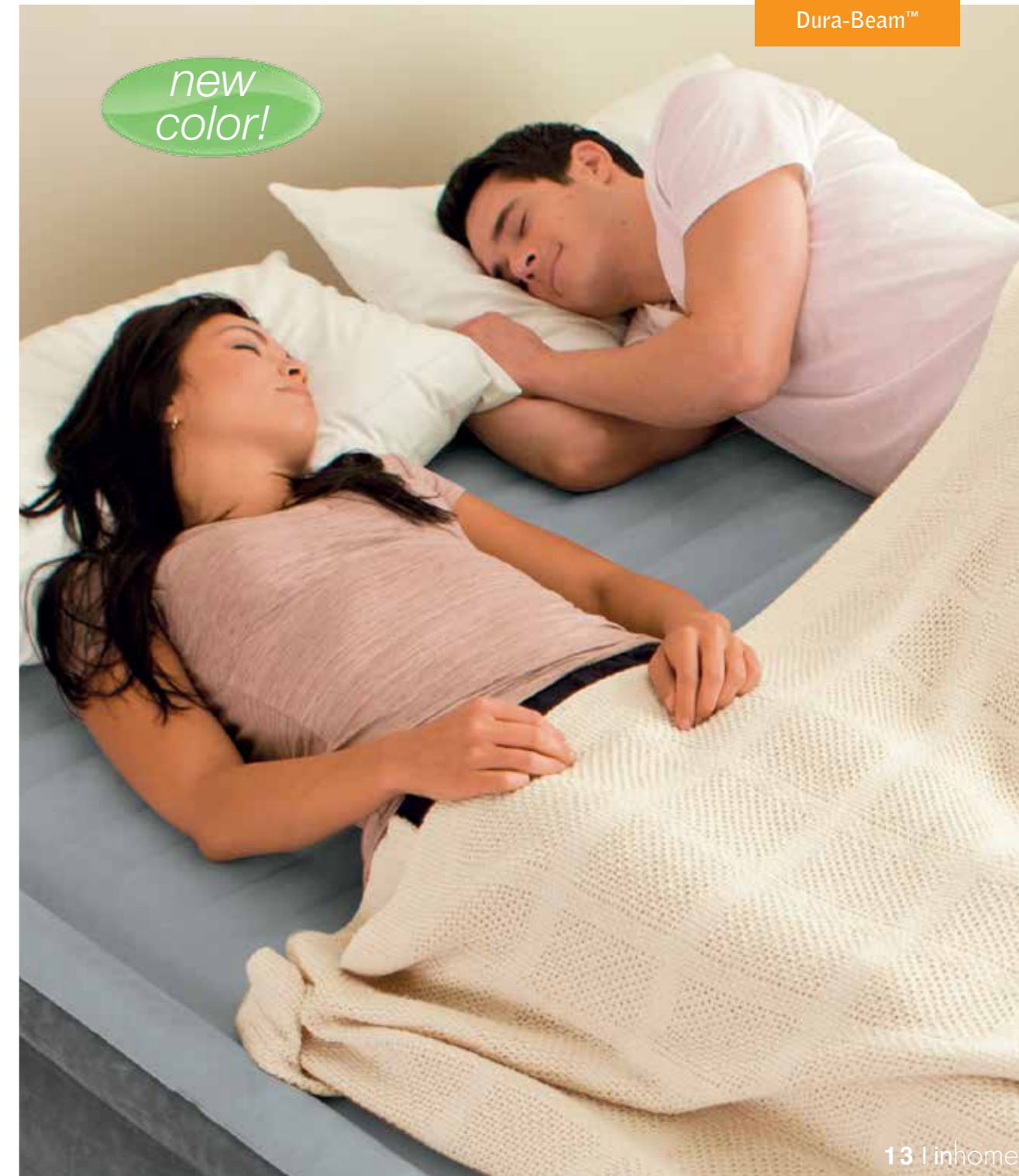
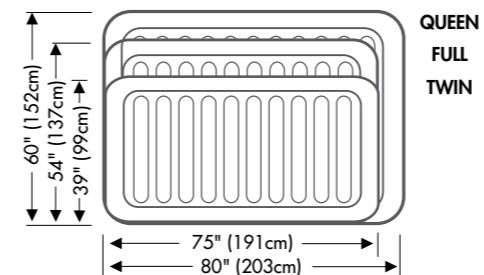

new color!

Dura-Beam™

COMFORT-PLUSH ELEVATED AIRBED

WITH DURA-BEAM™ CONSTRUCTION

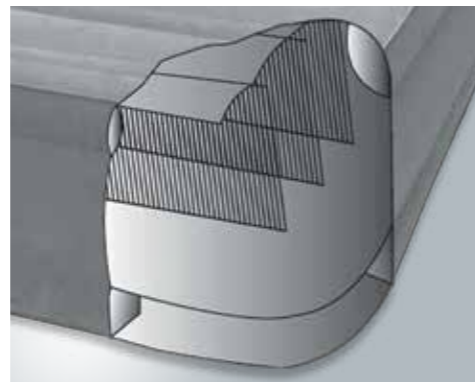

Patent pending Dura-Beam™ Construction



Built-in AC electric pump

AIRBED WITH BUILT-IN ELECTRIC PUMP

Item	Size	Approximate Inflated Size	Built-in Pump	Case Pack	Case Weight
64411 / E 64412	Twin	39" x 75" x 18" (99cm x 191cm x 46cm)	110 - 120V 220 - 240V	3 Ea.	41.9 Lb. (19.1kg)
64413 / E 64414	Queen	60" x 80" x 18" (152cm x 203cm x 46cm)	110 - 120V 220 - 240V	2 Ea.	38.5 Lb. (17.5kg)



18"
(46cm)
BED HEIGHT



INFLATING TIMES*	
AC Electric Pump	
Twin	2½ minutes
Queen	4 minutes

* Inflating time varies by mattress size and desired firmness

Our new Comfort-Plush Elevated Series is our latest edition to the revolutionary Dura-Beam™ Technology airbed line.

Innovative Dura-Beam™ Technology airbeds are comprised of thousands of high-strength polyester fibers. Unlike traditional airbed construction, these high-strength polyester fibers do not stretch over time, resulting in amazing durability for years of lasting comfort. Dura-Beam™ interior construction provides the ideal firmness for superb support and rejuvenating sleep.

Each bed is covered in plush flocking that is soft to the touch, and the horizontal air chambers provide added stability and support around the entire bed. The bed's elevated height makes it easier to get in and out of, much like a traditional mattress. For extra convenience, this bed comes with a powerful built-in electric pump for fast inflation and deflation.

Designed for Comfort. Engineered for Durability.

- Quality tested 21.2 gauge (0.53mm) waterproof flocked top and sides with 15 gauge (0.38mm) vinyl bottom
- 18" (46cm) Elevated Height
- Dura-Beam™ Construction
- Built-in electric pump
- Includes hand carry bag
- Folds compactly for storage or travel
- Air Lock Tested
- Shelf box

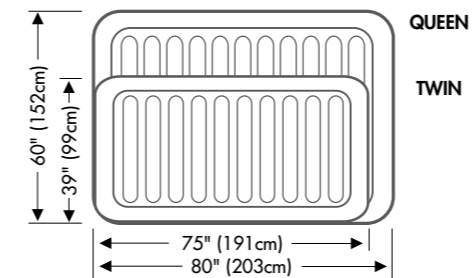

new!



COMFORT-PLUSH HIGH RISE AIRBED

WITH DURA-BEAM™ CONSTRUCTION

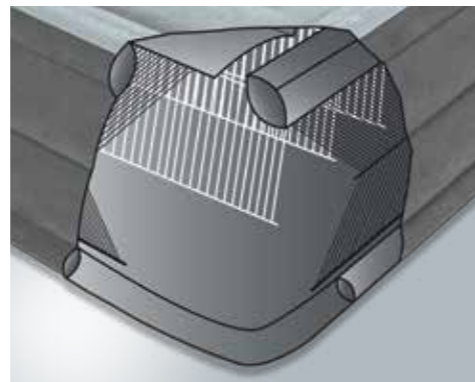

Patent pending
Dura-Beam™ Construction



Built-in
AC electric pump

AIRBED WITH BUILT-IN ELECTRIC PUMP

Item	Size	Approximate Inflated Size	Built-in Pump	Case Pack	Case Weight
64417 / E	Queen	60" x 80" x 22"	110 - 120V	2 Ea.	43.6 Lb. (19.8kg)
64418		(152cm x 203cm x 56cm)	220 - 240V		



22"
(56cm)
BED HEIGHT



INFLATING TIMES*	
AC Electric Pump	
110-120V	4½ minutes
220-240V	4½ minutes

* Inflating time varies by mattress size and desired firmness

Our new Comfort-Plush High Rise bed offers the perfect combination of luxurious comfort and convenience.

The revolutionary Dura-Beam™ interior construction provides the ideal comfort and firmness for a rejuvenating night's sleep. The horizontal air chambers provide added stability and support around the entire bed. The bed's elevated 22" height makes it easier to get in and out of, much like a traditional mattress.

The bed is covered in soft flocking for an extra comfortable sleeping surface. For added convenience, this bed comes with a powerful built-in electric pump for fast inflation and deflation.

Designed for Comfort. Engineered for Durability.

- Quality tested 21.2 gauge (0.53mm) waterproof flocked top and 22.4 gauge (0.56mm) sides with 16.8 gauge (0.42mm) vinyl bottom
- 22" (56cm) High Rise Height
- Dura-Beam™ Construction
- Built-in electric pump
- Includes hand carry bag
- Folds compactly for storage or travel
- Air Lock Tested
- Shelf box

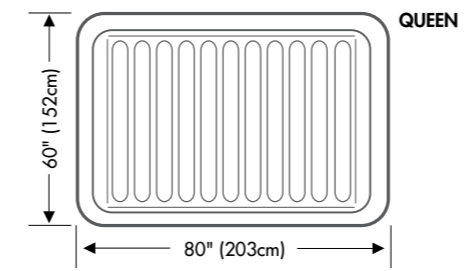

new!

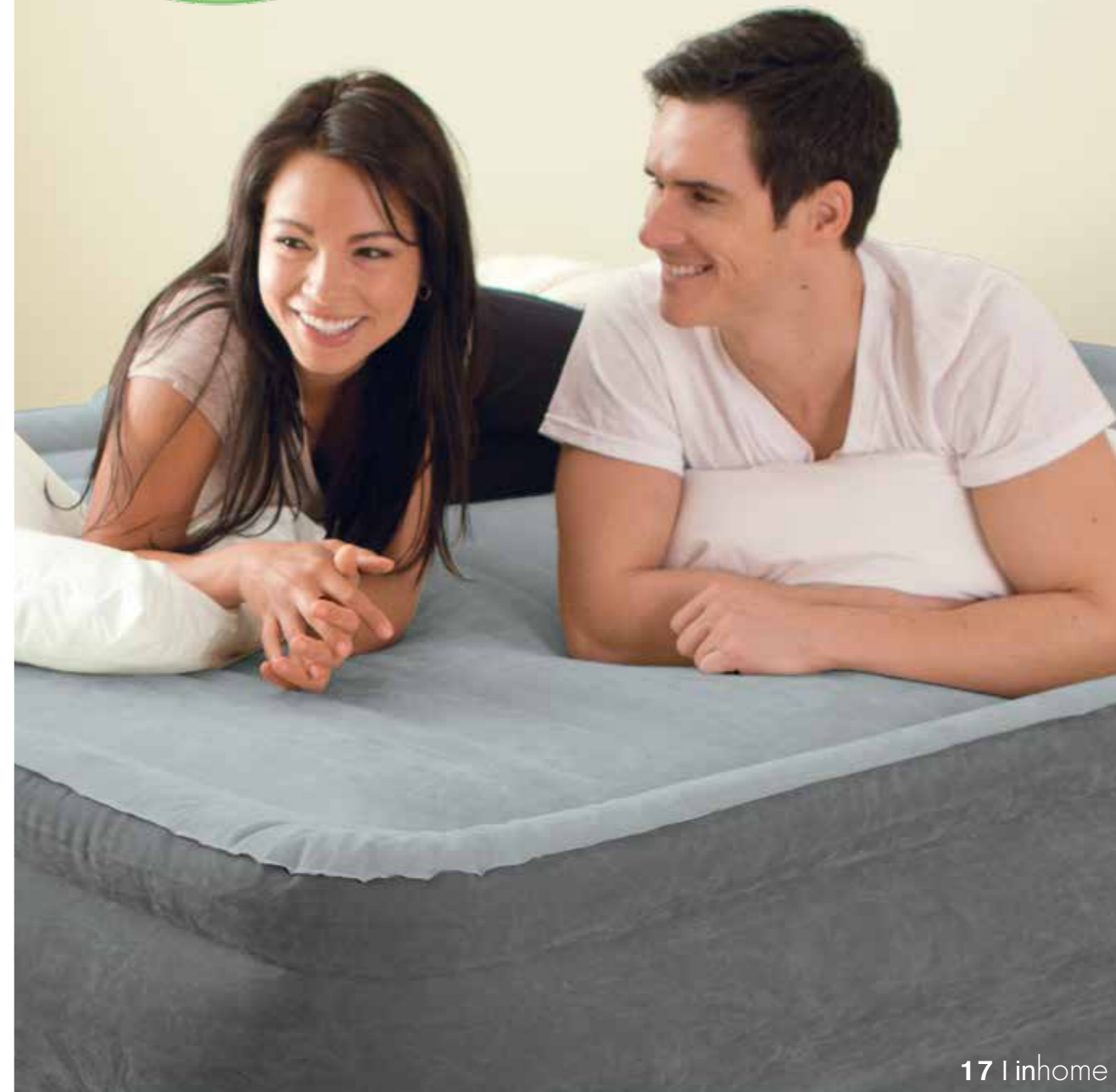

PREMIUM COMFORT AIRBED

WITH DURA-BEAM™ CONSTRUCTION

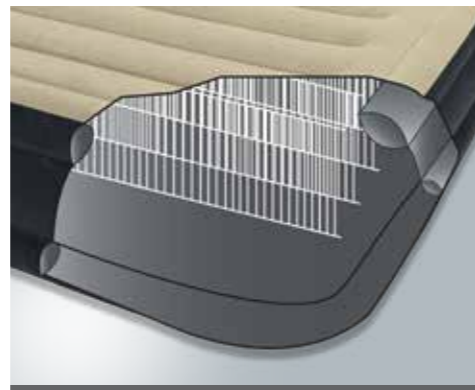

Patent pending Dura-Beam™ Construction



Built-in AC electric pump

AIRBED WITH BUILT-IN ELECTRIC PUMP

Item	Size	Approximate Inflated Size	Built-in Pump	Case Pack	Case Weight
64403 / E 64404	Queen	60" x 80" x 16" (152cm x 203cm x 41cm)	110 - 120V 220 - 240V	2 Ea.	34.3 Lb. (15.6kg)
64407 / E 64408	Queen	60" x 80" x 20" (152cm x 203cm x 51cm)	110 - 120V 220 - 240V	2 Ea.	36.7 Lb. (16.7kg)



16" / 20"
(41cm/51cm)
BED HEIGHT
with Built-in
Pillow

INFLATING TIMES*	
AC Electric Pump	
16" (41cm)	3½ minutes
20" (51cm)	4 minutes

* Inflating time varies by mattress size and desired firmness

Our Premium Comfort Pillow Rest Series offers the perfect airbed for overnight guests or an upcoming vacation.

Innovative Dura-Beam™ Technology airbeds are comprised of thousands of high-strength polyester fibers. Unlike traditional airbed construction, these high-strength polyester fibers do not stretch over time, resulting in amazing durability for years of lasting comfort. Dura-Beam™ interior construction provides the ideal firmness for superb support and rejuvenating sleep.

Each bed is covered in soft flocking for extra comfort and the horizontal air chambers provide added stability and support around the entire bed. The bed's built-in pillow makes it the ideal for everyday indoor and outdoor use. For extra convenience, this bed comes with a powerful built-in electric pump for fast inflation and deflation.

Designed for Comfort. Engineered for Durability.

- Quality tested 22.4 gauge (0.56mm) waterproof flocked top and 21.2 gauge (0.53mm) sides with 16 gauge (0.40mm) vinyl bottom
- Includes Pillow Rest
- Dura-Beam™ Construction
- Mattress is raised 13" (33cm) and 18" (46cm) from the floor respectively
- Built-in electric pump
- Includes hand carry bag
- Folds compactly for storage or travel
- Air Lock Tested
- Shelf box

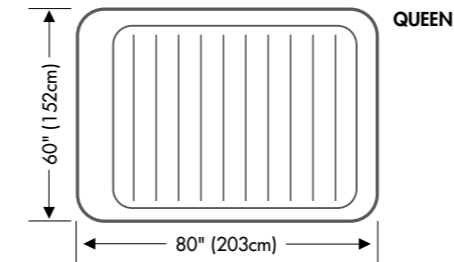

new!



CAMPING

Enjoy the Great Outdoors

Intex knows that disconnecting from the pace of modern life doesn't mean giving up comfort. Intex Camping Airbeds have all been specifically designed to provide an uncompromising level of style, durability, comfort, and ease. Intex Camping Airbeds come in a variety of shapes, sizes, and styles to suit nearly any outdoor adventure.



100% of our airbeds are quality tested to be air tight before they leave our factory.

CAMPING MATS

A quick, simple and lightweight sleeping solution while camping. Wave beam construction for a uniform sleeping surface. Intex camping mats provide comfort and durability for outside conditions.

LAMINATED FABRIC TOPS FOR DURABILITY

- Laminated vinyl to withstand the elements
- Each mat has a unique construction that helps provide more comfort to campers
- Folds compactly for easy storage or travel
- Topped with fabric to ensure sleeping comfort
- Shelf box



CAMPING MAT

Item	Approximate Inflated Size	Case Pack	Case Weight
68797 / E	72½" x 26½" x 6¾" (184cm x 67cm x 17cm)	6 Ea.	19.1 Lb. (8.7kg)
68798 / E	74½" x 28½" x 8" (189cm x 72cm x 20cm)	6 Ea.	26.0 Lb. (11.8kg)
68799 / E	76" x 50" x 9½" (193cm x 127cm x 24cm)	3 Ea.	22.3 Lb. (10.1kg)

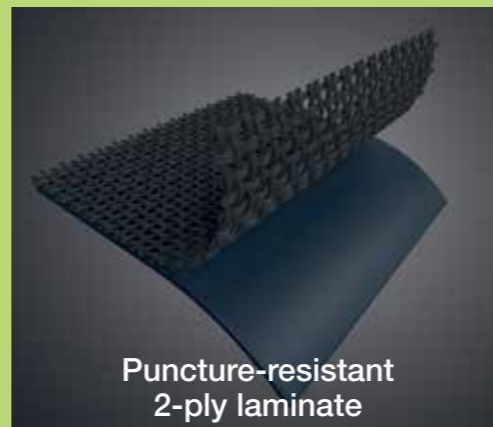
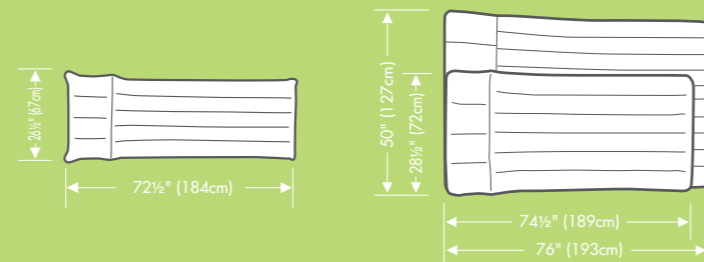

DOWNY BED

This airbed has a flocked top that provides a more comfortable sleeping surface. Its unique wave beam construction eliminates uncomfortable surface bumps and provides a flat, uniform sleeping surface. The Downy airbed can be inflated with either the built-in manual foot pump or a regular pump.

BUILT-IN FOOT PUMP FOR CONVENIENCE

- Quality tested 20.8 gauge (0.52mm) waterproof flocked top with 15 gauge (0.38mm) vinyl sides and bottom
- Unique built-in bellow foot pump for convenience-no separate pump needed. Just step down to inflate and the pump springs back automatically for the next cycle
- New and improved foot pump construction allows for faster inflation
- 2-in-1 valve for inflating with optional electric or manual pumps
- Conventional mattress sizes (L x W) for more sleeping area and a better fit for sheets
- 8¾" (22cm) mattress thickness for extra soft comfort
- Shelf box

AIRBED WITH BUILT-IN FOOT PUMP

Item	Size	Approximate Inflated Size	Case Pack	Case Weight
66950 / E	Jr. Twin	30" x 75" x 8¾" (76cm x 191cm x 22cm)	6 Ea.	31.2 Lb. (14.2kg)
66927 / E	Twin	39" x 75" x 8¾" (99cm x 191cm x 22cm)	4 Ea.	29.8 Lb. (13.5kg)
66928 / E	Full	54" x 75" x 8¾" (137cm x 191cm x 22cm)	3 Ea.	28.3 Lb. (12.9kg)
66929 / E	Queen	60" x 80" x 8¾" (152cm x 203cm x 22cm)	3 Ea.	32.3 Lb. (14.7kg)



Wave Beam Construction
U.S. Patent No. D414,644



Built-in lightweight foot pump for easy inflation - No separate pump or power supply needed!

INFLATING TIMES*

Jr. Twin	2 minutes
Twin	2 minutes
Full	3 minutes
Queen	4 minutes

* Inflating time varies by mattress size and desired firmness

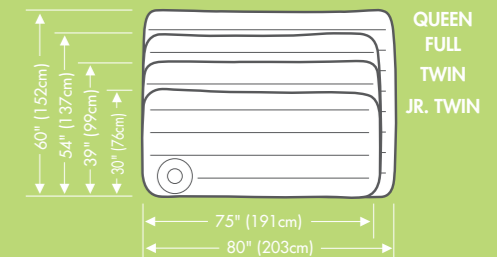

PRESTIGE DOWNY BED

AIRBED WITH SEPARATE BATTERY PUMP (6 X C-CELL)

Item	Size	Approximate Inflated Size	Case Pack	Case Weight
66967 / E	Twin	39" x 75" x 8¾" (99cm x 191cm x 22cm)	4 Ea.	30.4 lb. (13.8kg)
66968 / E	Full	54" x 75" x 8¾" (137cm x 191cm x 22cm)	3 Ea.	29.0 lb. (13.2kg)
66969 / E	Queen	60" x 80" x 8¾" (152cm x 203cm x 22cm)	3 Ea.	33.4 lb. (15.2kg)

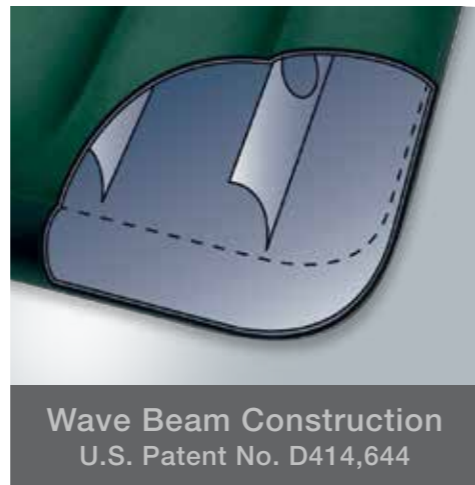

Wave Beam Construction
U.S. Patent No. D414,644



For home or camping
Operates on 6 C-cell batteries
(not included)



The perfect
camping companion

INFLATING TIMES*	
Twin	2 minutes
Full	2 minutes
Queen	2½ minutes

* Inflating time varies by mattress size and desired firmness

The perfect choice for the rugged outdoors. The flocked top provides a comfortable sleeping surface, cleans easily and is waterproof for camping. The powerful battery-operated (6 x C-cell) pump goes anywhere!

WITH HAND-HELD BATTERY PUMP

- Quality tested 20.8 gauge (0.52mm) waterproof flocked top with 15 gauge (0.38mm) vinyl sides and bottom
- 3-in-1 valve has extra-wide openings for fast inflating and deflating
- Conventional mattress sizes (L x W) for more sleeping area and a better fit for sheets
- Battery pump can also be used on other inflatables
- 8¾" (22cm) mattress thickness for extra soft comfort
- Folds compactly for storage or travel
- Shelf box

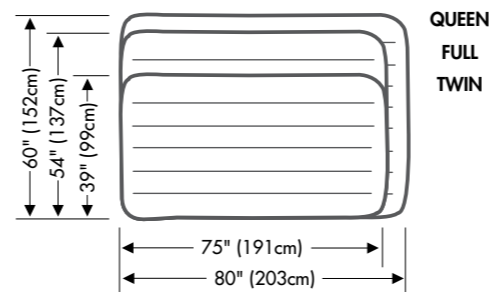

CLASSIC DOWNY BED

For indoor and outdoor use.

AIRBED ONLY

Item	Size	Approximate Inflated Size	Case Pack	Case Weight
68950 / E	JR. Twin	30" x 75" x 8¾" (76cm x 191cm x 22cm)	6 Ea.	31.2 Lb. (14.2kg)
68757 / E	Twin	39" x 75" x 8¾" (99cm x 191cm x 22cm)	4 Ea.	26.1 Lb. (11.9kg)
68758 / E	Full	54" x 75" x 8¾" (137cm x 191cm x 22cm)	3 Ea.	25.9 Lb. (11.8kg)
68759 / E	Queen	60" x 80" x 8¾" (152cm x 203cm x 22cm)	3 Ea.	30.6 Lb. (13.9kg)
68755 / E	King	72" x 80" x 8¾" (183cm x 203cm x 22cm)	2 Ea.	23.8 Lb. (10.8kg)

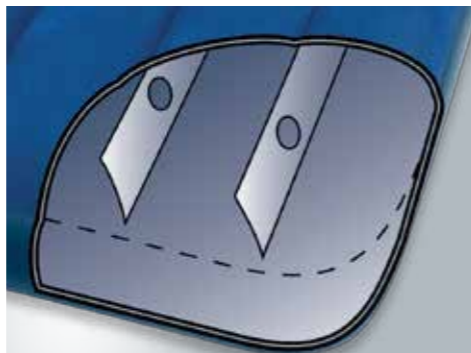

Wave Beam Construction
U.S. Patent No. D414,644

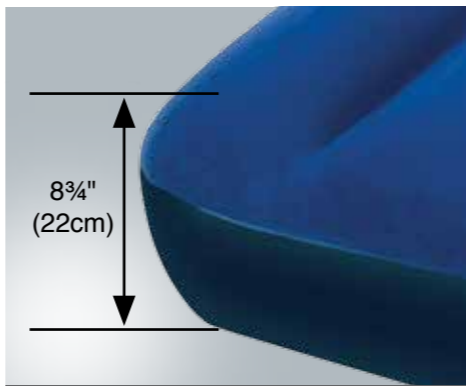

8¾"
(22cm)

Bed Height

AIRBED SET

Includes two I-beam pillows 17" x 11" 3½" (43cm x 28cm x 9cm) and a #68612 Double-Quick air pump

Item	Size	Approximate Inflated Size	Hand Pump	Case Pack	Case Weight
68765 / E	Queen	60" x 80" x 8¾" (152cm x 203cm x 22cm)	68612	3 Ea.	34.9 Lb. (15.9kg)

2-in-1 Valve

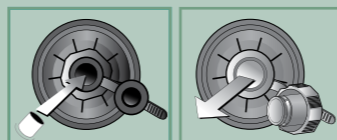

Extra-wide valve openings for fast inflating and deflating

You can't go wrong with this bed! Take it camping or use it for out of town guests. Our best selling Classic Downy Bed is versatile and perfect for both in-home and camping. The wave beam construction creates a uniform sleeping surface that is guaranteed to give you a good night's rest wherever you are. Plush flocking provides a luxurious sleeping surface while keeping sheets in place. It's also easy to clean and waterproofed for camping use. The Classic Downy Bed offers retailers and consumers the best value for their money at an opening price point.

PLUSH FLOCKED TOP FOR COMFORT

- Quality tested 20.8 gauge (0.52mm) waterproof flocked top with 15 gauge (0.38mm) vinyl sides and bottom
- 2-in-1 valve has extra-wide openings for fast inflating and deflating
- Conventional mattress sizes (L x W) for more sleeping area and a better fit for sheets
- 8¾" (22cm) mattress thickness for extra soft comfort
- Folds compactly for storage or travel
- Shelf box

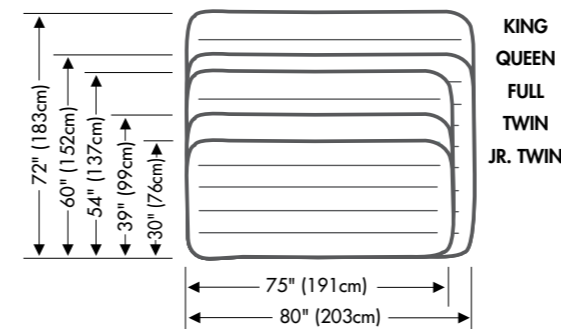

SINGLE

Comfort On the Go

With all of the demands of modern life, travel, whether for work or personal, has become a necessity. Intex Single Airbeds allow the modern traveler a way of taking a little bit of home with them in a compact and comfortable airbed. Let Intex make you feel at home.



100% of our airbeds are quality tested to be air tight before they leave our factory.

2-IN-1 AIRBED

AIRBED ONLY

Item	Size	Approximate Inflated Size	Case Pack	Case Weight
67743 / E	Twin	39" x 75" x 18" (99cm x 191cm x 46cm)	3 Ea.	45.6 Lb. (20.7kg)
67744 / E	Queen	60" x 80" x 18" (152cm x 203cm x 46cm)	2 Ea.	44.4 Lb. (20.2kg)

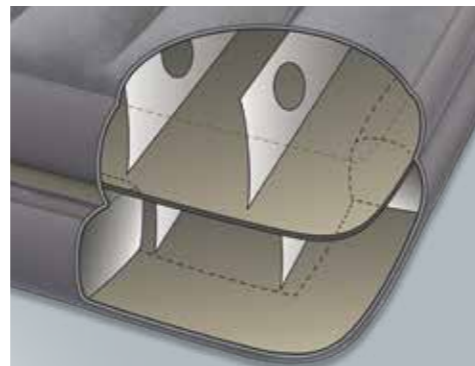

Wave Beam Construction
U.S. Patent No. D414,644



Easy snap-buckles convert
one bed into two beds!

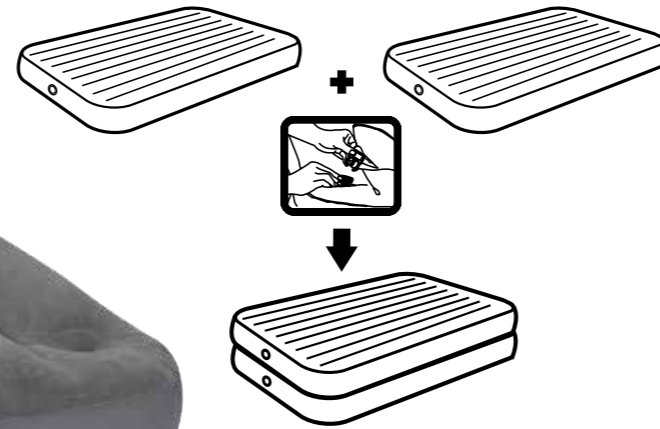

2-in-1 Valve

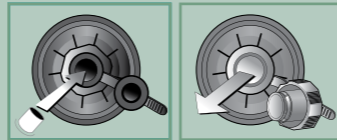

Extra-wide valve openings for
fast inflating and deflating

Our 2-in-1 Bed is still the most flexible, all-purpose airbed: Two beds in one! Attached by four snap-buckles, it easily converts from a flocked high-rise bed into two single height beds. Both beds have plush flocked surfaces for soft comfort and provide a restful night's sleep. It's incredibly easy to maintain and is the perfect bed for consumers who have multiple house guests, for kids' sleepovers and for family camping trips. Its versatility makes it one of the most popular beds in our collection!

ELEVATED BED CONVERTS TO TWO SEPARATE BEDS

- Quality tested 20.8 gauge (0.52mm) waterproof flocked top with 15 gauge (0.38mm) vinyl sides and bottom
- 2-in-1 valve has extra-wide openings for fast inflating and deflating
- Four snap-buckles turn 1 high-rise bed into 2 single layer beds for more guests
- Dual wave beam construction provides an added level of sleeping comfort
- Flocked sleeping surface for extra comfort all night long
- Conventional mattress sizes (L x W) for more sleeping area and a better fit for sheets
- Folds compactly for easy storage or travel
- Shelf box

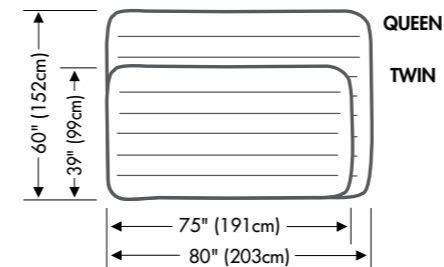

PILLOW REST CLASSIC BED



Wave Beam Construction
U.S. Patent No. D414,644



Built-in
AC Electric Pump

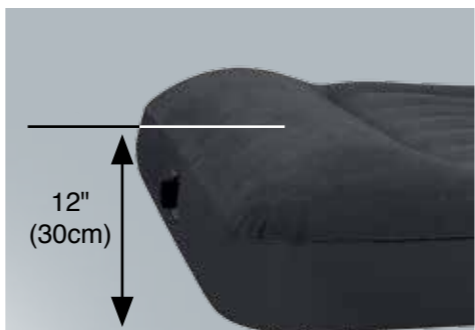

Built-in pillow for
added convenience



INFLATING TIMES*

AC Electric Pump	
Twin	1 minute
Full	1½ minutes
Queen	1¾ minutes

* Inflating time varies by mattress size and desired firmness

For those who need a pillow but lack the space to carry one, this luxurious flocked bed is the answer. The waterproof and stain resistant surface makes it easy to keep clean while providing the soft comfort of home.

ELEVATED FOR CONVENIENCE

- Quality tested 21.2 gauge (0.53mm) waterproof flocked top with 15 gauge (0.38mm) vinyl sides and bottom
- Flocked sleeping surface for extra comfort
- A built-in pillow provides bed-like comfort
- Mattress is raised 9" (23cm) from the floor for convenience
- 3-in-1 valve on "Airbed Only" series has extra-wide openings
- Inflated dimensions fit standard sheet sizes
- Includes carry bag
- Shelf box

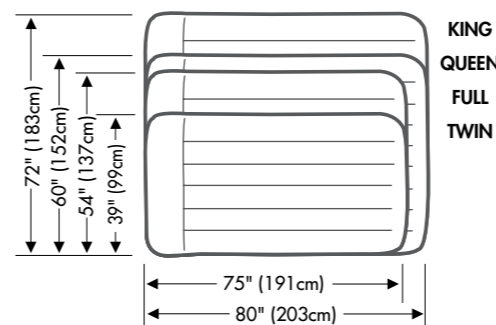

AIRBED ONLY

Item	Size	Approximate Inflated Size	Case Pack	Case Weight
66767 / E	Twin	39" x 75" x 12" (99cm x 191cm x 30cm)	4 Ea.	28.4 Lb. (12.9kg)
66768 / E	Full	54" x 75" x 12" (137cm x 191cm x 30cm)	3 Ea.	28.4 Lb. (12.9kg)
66769 / E	Queen	60" x 80" x 12" (152cm x 203cm x 30cm)	3 Ea.	33.8 Lb. (15.4kg)
66770 / E	King	72" x 80" x 12" (183cm x 203cm x 30cm)	2 Ea.	26.9 Lb. (12.2kg)

AIRBED WITH BUILT-IN ELECTRIC PUMP

Item	Size	Approximate Inflated Size	Built-in Pump	Case Pack	Case Weight
66775 / E 66779	Twin	39" x 75" x 12" (99cm x 191cm x 30cm)	110 – 120V 220 – 240V	4 Ea.	36.8 Lb. (16.7kg)
66776 / E 66780	Full	54" x 75" x 12" (137cm x 191cm x 30cm)	110 – 120V 220 – 240V	3 Ea.	34.7 Lb. (15.8kg)
66777 / E 66781	Queen	60" x 80" x 12" (152cm x 203cm x 30cm)	110 – 120V 220 – 240V	3 Ea.	41.1 Lb. (18.7kg)



PILLOW REST MID-RISE BED

AIRBED WITH BUILT-IN ELECTRIC PUMP

Item	Size	Approximate Inflated Size	Built-in Pump	Case Pack	Case Weight
67741 / E 67742	Twin	39" x 75" x 15" (99cm x 191cm x 38cm)	110 - 120V 220 - 240V	3 Ea.	32.1 lb. (14.6kg)
67747 / E 67748	Queen	60" x 80" x 15" (152cm x 203cm x 38cm)	110 - 120V 220 - 240V	2 Ea.	31.7 lb. (14.4kg)

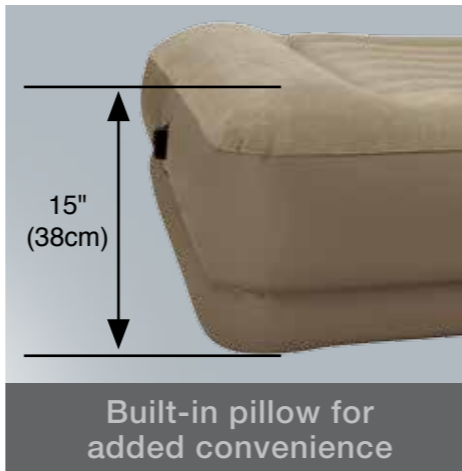

INFLATING TIMES*	
AC Electric Pump	
Twin	1 1/4 minutes
Queen	3 minutes

* Inflating time varies by mattress size and desired firmness

Our mid-rise airbed provides all of the great benefits of our high-rise airbed, but with the added advantage of lighter weight and easier portability. The bed features a contoured bottom which provides a better gripping effect to increase stability. Perfect for travelers who are looking for all of the comforts of a raised bed, plus the convenience of easy transportation. Twin size is also available.

ELEVATED FOR CONVENIENCE

- Quality tested 21.2 gauge (0.53mm) waterproof flocked top with 15 gauge (0.38mm) vinyl sides and bottom
- Flocked sleeping surface for extra comfort
- A built-in pillow provides bed-like comfort
- Mattress is raised 13 3/4" (35cm) from the floor for convenience
- Inflated dimensions fit standard sheet sizes
- Includes hand carry bag
- Shelf box

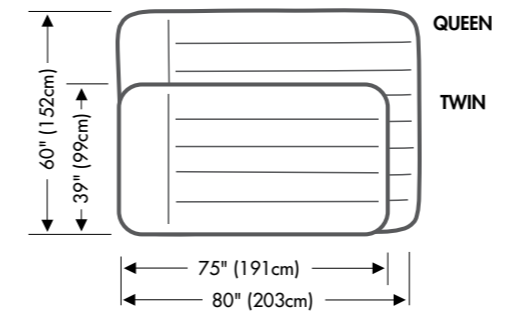

INTEX®

DELUXE MID RISE PILLOW REST BED

AIRBED WITH HAND-HELD AC PUMP

Item	Size	Approximate Inflated Size	Hand-held Pump	Case Pack	Case Weight
67725 / E	Queen	60" x 80" x 16" (152cm x 203cm x 41cm)	110 - 120V 220 - 240V	2 Ea.	36.5 lb. (16.6kg)
67726					

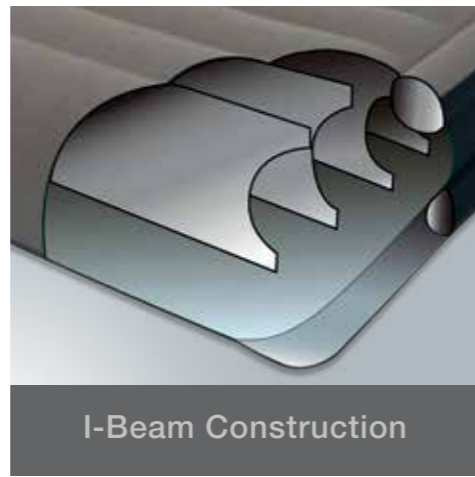

I-Beam Construction

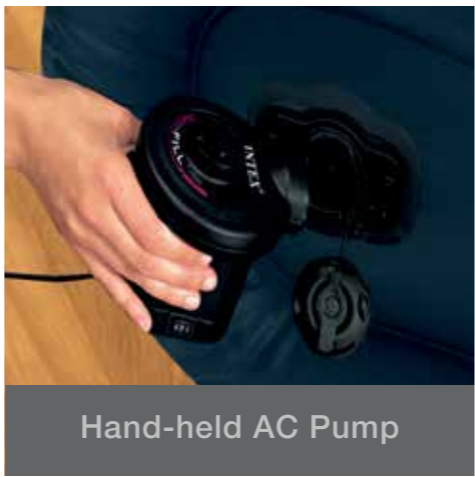

Hand-held AC Pump



Revolutionary textured flocking feels like real corduroy!



**16"
(41cm)**
BED HEIGHT
with Built-in
Pillow

INFLATING TIMES*	
AC Electric Pump	
110-120V	2 minutes
220-240V	2 minutes

* Inflating time varies by mattress size and desired firmness

Introducing a revolutionary new flocking with the luxurious feel of velveteen corduroy! This bed has an elegant look to match. The I-Beam construction offers great stability as well as comfort to make this airbed a refined addition to any guest room.

DESIGNER ELEGANCE

- Quality tested 26.4 gauge (0.66mm) waterproof flocked top with 15 gauge (0.38mm) vinyl sides and bottom
- Sturdy I-Beam construction
- Mattress is raised 13" (33cm) from the floor for convenience
- Folds compactly for storage
- Includes hand carry bag
- Shelf box

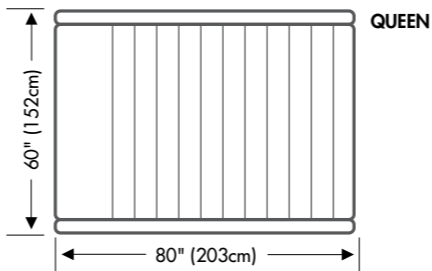



RAISED

Stylish. Convenient. Comfort.

Intex Raised Airbeds are the perfect combination of form, function, style and comfort. Flocked surfaces and elevated airbed heights allow guests to enjoy a restful night's sleep away from home. Intex Raised Airbeds come in a variety of sizes to suit any room and allow hosts to create a cozy environment for their overnight guests.



100% of our airbeds are quality tested to be air tight before they leave our factory.

PILLOW REST RAISED BED

AIRBED ONLY

Item	Size	Approximate Inflated Size	Case Pack	Case Weight
66721 / E	Twin	39" x 75" x 18½" (99cm x 191cm x 47cm)	3 Ea.	32.8 Lb. (14.9kg)
66720 / E	Queen	60" x 80" x 18½" (152cm x 203cm x 47cm)	2 Ea.	34.7 Lb. (15.8kg)

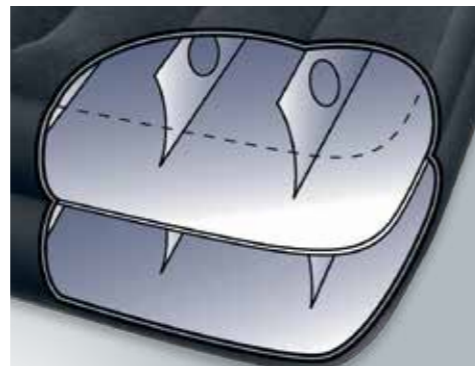

Wave Beam Construction
U.S. Patent No. D414,644



Built-in
AC Electric Pump

AIRBED WITH BUILT-IN ELECTRIC PUMP

Item	Size	Approximate Inflated Size	Built-in Pump	Case Pack	Case Weight
66705 / E 66706	Twin	39" x 75" x 18½" (99cm x 191cm x 47cm)	110 - 120V 220 - 240V	3 Ea.	39.7 Lb. (18.1kg)
67701 / E 66702	Queen	60" x 80" x 18½" (152cm x 203cm x 47cm)	110 - 120V 220 - 240V	2 Ea.	39.1 Lb. (17.8kg)



18½"
(47cm)
BED HEIGHT
with Built-in
Pillow

INFLATING TIMES*	
AC Electric Pump	
Twin	2½ minutes
Queen	4 minutes

* Inflating time varies by mattress size and desired firmness

The Pillow Rest Raised Bed is our best selling raised airbed. By providing all of the great benefits of a raised bed and built-in pump, this bed is perfect for house guests, dorm rooms and even camping trips! It's light, convenient and with a built-in pillow, it's as comfortable as your bed at home. This bed is truly a great value at a great price.

ELEVATED FOR CONVENIENCE

- Quality tested 21.2 gauge (0.53mm) waterproof flocked top with 15 gauge (0.38mm) vinyl sides and bottom
- Mattress is raised 16½" (42cm) from the floor for convenience
- 3-in-1 valve on "Airbed Only" series has extra-wide openings
- A built-in pillow provides bed-like comfort
- Includes hand carry bag
- Shelf box

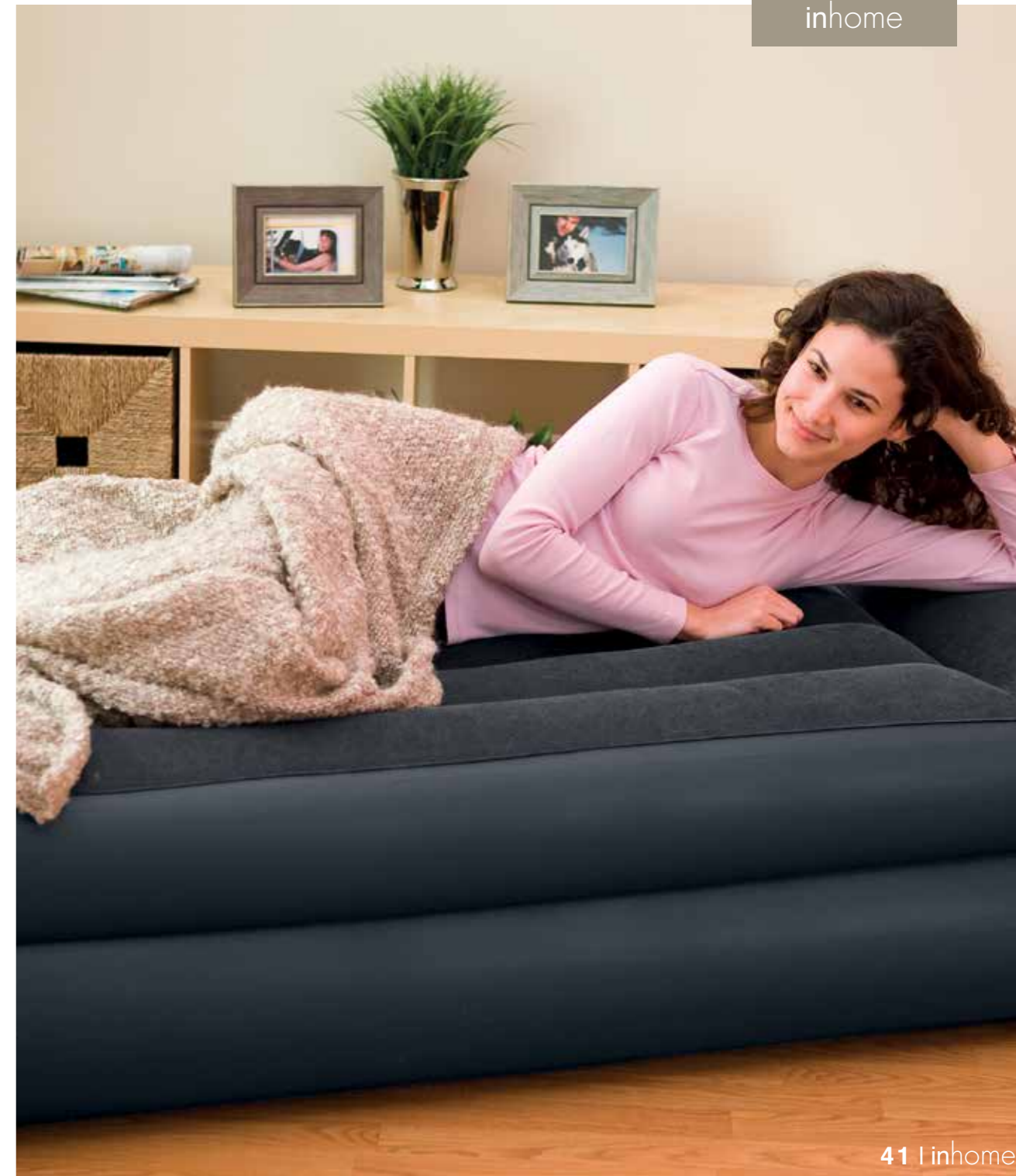
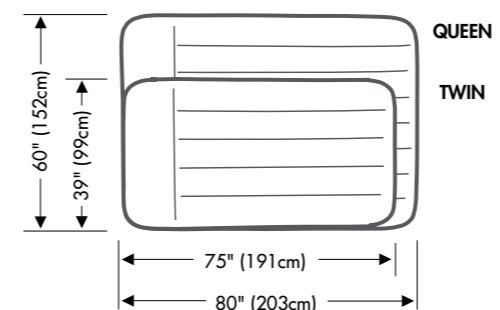

PILLOW REST RAISED BED

AIRBED WITH BUILT-IN ELECTRIC PUMP

Item	Size	Approximate Inflated Size	Built-in Pump	Case Pack	Case Weight
67713 / E 67714	Queen	60" x 80" x 18½" (152cm x 203cm x 47cm)	110 - 120V 220 - 240V	2 Ea.	39.1 lb. (17.8kg)

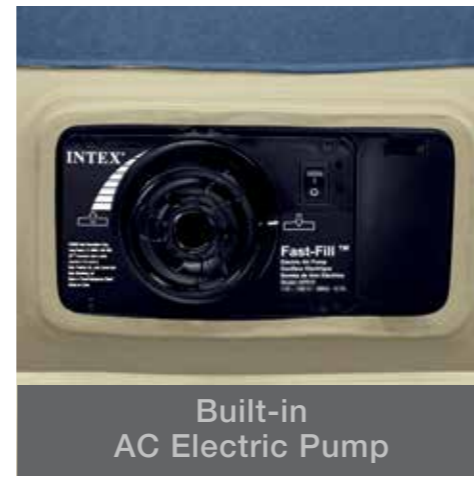
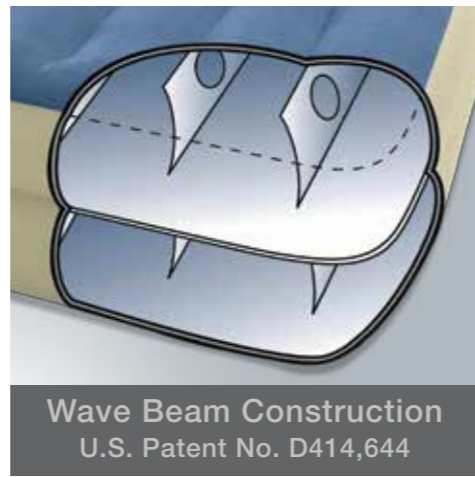

Our evergreen Pillow Rest Raised Bed is now also available in this fashion-forward two-toned color combination. This attractive periwinkle blue and sand combination is sure to be a great addition to any room.

ELEVATED FOR CONVENIENCE

- Quality tested 21.2 gauge (0.53mm) waterproof flocked top with 15 gauge (0.38mm) vinyl sides and bottom
- Mattress is raised 16½" (42cm) from the floor for convenience
- A built-in pillow provides bed-like comfort
- Includes hand carry bag
- Shelf box



18½" (47cm)
BED HEIGHT
with Built-in Pillow

INFLATING TIMES*	
AC Electric Pump	
110V-120V	4 minutes
220V-240V	4 minutes

* Inflating time varies by mattress size and desired firmness

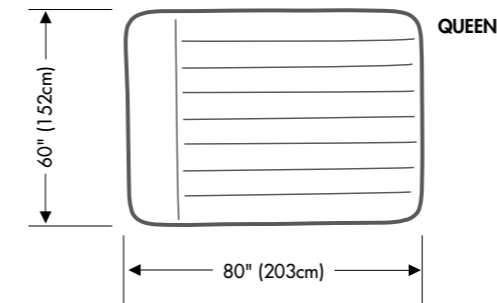

DELUXE PILLOW REST RAISED BED

AIRBED ONLY

Item	Size	Approximate Inflated Size	Case Pack	Case Weight
67736 / E	Queen	60" x 80" x 19" (152cm x 203cm x 48cm)	2 Ea.	32.8 Lb. (14.9kg)

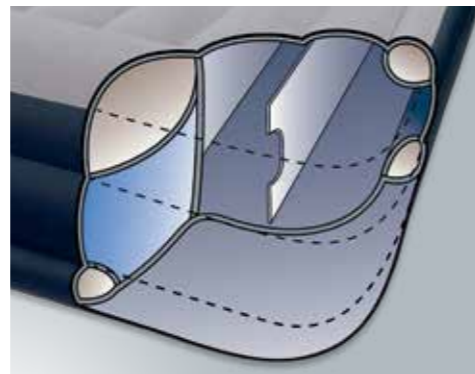

Deluxe Pillow Rest Construction



Built-in AC Electric Pump

AIRBED WITH BUILT-IN ELECTRIC PUMP

Item	Size	Approximate Inflated Size	Built-in Pump	Case Pack	Case Weight
67731 / E 67732	Twin	39" x 75" x 19" (99cm x 191cm x 48cm)	110 - 120V 220 - 240V	3 Ea.	39.2 Lb. (17.8kg)
67737 / E 67738	Queen	60" x 80" x 19" (152cm x 203cm x 48cm)	110 - 120V 220 - 240V	2 Ea.	37.3 Lb. (16.9kg)



19" (48cm)
BED HEIGHT
with Built-in Pillow

INFLATING TIMES*	
AC Electric Pump	
Twin	2 minutes
Queen	3½ minutes

* Inflating time varies by mattress size and desired firmness

A deluxe version of our best selling Pillow Rest Raised Bed! This style features an outer perimeter frame on the sleeping surface that provides added stability. This outer frame prevents your guests from accidentally rolling off – especially useful when the bed sleeps two! The two-tone color is pleasing to the eye and the soft plush flocking of the built-in pillow makes this bed a premium sleeping experience.

BUILT-IN PILLOW AND SOFT FLOCKED TOP FOR COMFORT

- Quality tested 21.2 gauge (0.53mm) waterproof flocked top with 15 gauge (0.38mm) vinyl sides and bottom
- 3-in-1 valve on "Airbed Only" series has extra-wide openings for fast inflating and deflating
- Mattress is raised 16¾" (43cm) from the floor for convenience
- Indented sides to better grip standard size sheets
- Includes hand carry bag
- Shelf box

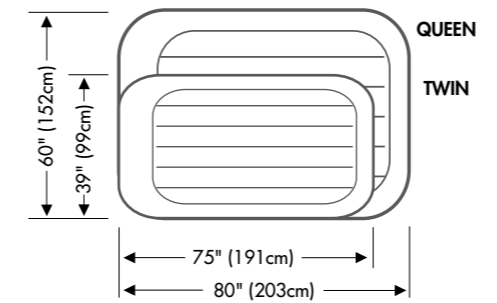

RAISED DOWNY BED

AIRBED WITH BUILT-IN ELECTRIC PUMP

Item	Size	Approximate Inflated Size	Built-in Pump	Case Pack	Case Weight
66717 / E 66718	Queen	60" x 80" x 22" (152cm x 203cm x 56cm)	110 - 120V 220 - 240V	2 Ea.	46.7 lb. (21.2kg)

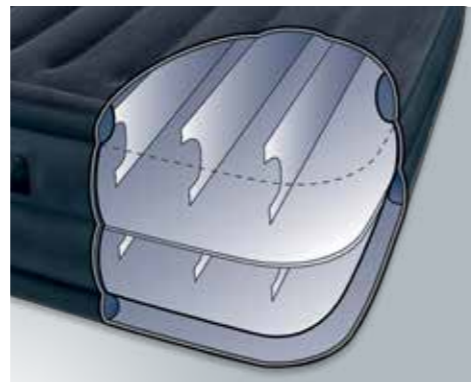

Double-Layered Wave Beam Construction



Built-in AC Electric Pump



22"
(56cm)
BED HEIGHT

INFLATING TIMES*	
AC Electric Pump	
110V-120V	5 minutes
220V-240V	5 minutes

* Inflating time varies by mattress size and desired firmness

Our Raised Downy Bed is the perfect bed for consumers who are used to sleeping on raised surfaces. Your house guests will love the support and firmness created by the dual chamber construction. Indented sides help grip fitted sheets. The outer perimeter frame on both top and bottom provides additional stability and support making this bed the ultimate Comfort Rest™ experience.

ELEVATED FOR COMFORT & CONVENIENCE

- Quality tested 21.2 gauge (0.53mm) waterproof flocked top with 15 gauge (0.38mm) vinyl sides and bottom
- Dual-chamber construction. The lower chamber functions as the box spring form on a traditional bed, providing extra firmness and support. The upper chamber functions as a mattress
- 60" x 80" (152cm x 203cm) queen-sized mattress is raised 22" (56cm) from the floor for convenience
- Cozy flocked mattress top
- Deflates completely for travel and storage
- Includes hand carry bag
- Shelf box

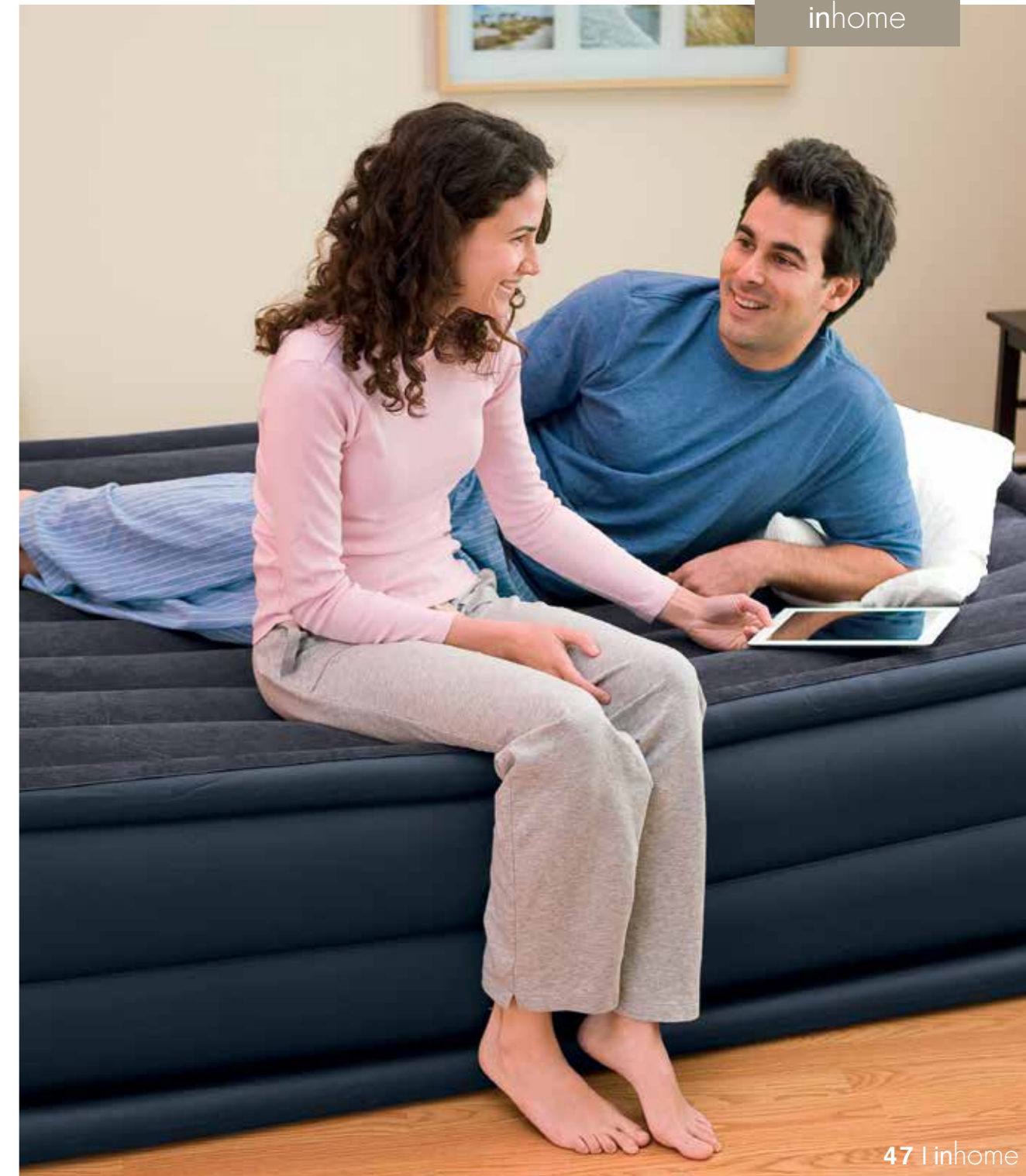
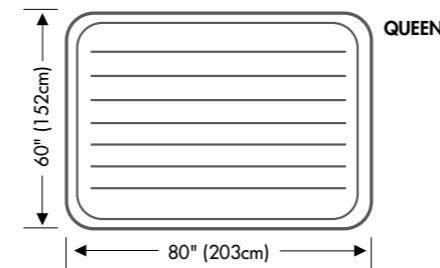

Plush Bed

AIRBED WITH BUILT-IN ELECTRIC PUMP

Item	Size	Approximate Inflated Size	Built-in Pump	Case Pack	Case Weight
67709 / E 67710	Queen	60" x 80" x 18" (152cm x 203cm x 46cm)	110 - 120V 220 - 240V	2 Ea.	47.6 lb. (21.6kg)

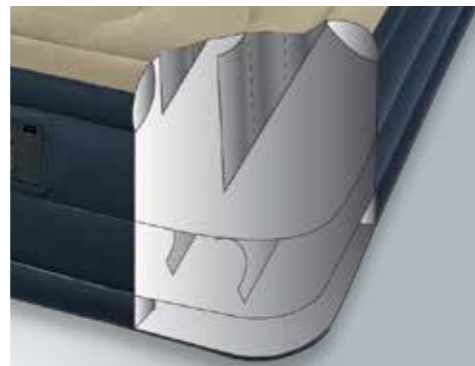

Double-Layered I-Beam Construction
U.S. Patent No. 6,568,011



Built-in AC Electric Pump



18"
(46cm)
BED HEIGHT

INFLATING TIMES*	
AC Electric Pump	
110V-120V	4 minutes
220V-240V	4 minutes

* Inflating time varies by mattress size and desired firmness

With the success of our Ultra Plush Bed, we introduce a complementary series at a lower price point. This Plush Bed offers the same comfort, convenience, and great look of the original Ultra-Plush bed, but with vinyl sides, at a lower price point.

ELEVATED WITH BUILT-IN ELECTRIC PUMP

- Quality tested 21.2 gauge (0.53mm) with 15 gauge (0.38mm) vinyl sides and bottom
- Dual chamber construction with I-Beam base and complementing S-Beam in upper chamber for comfort and stability
- Mattress is raised 18" (46 cm) from the floor for convenience
- Mattress quickly and easily inflates and deflates with a high-powered built-in electric pump
- Includes hand carry bag
- Shelf box

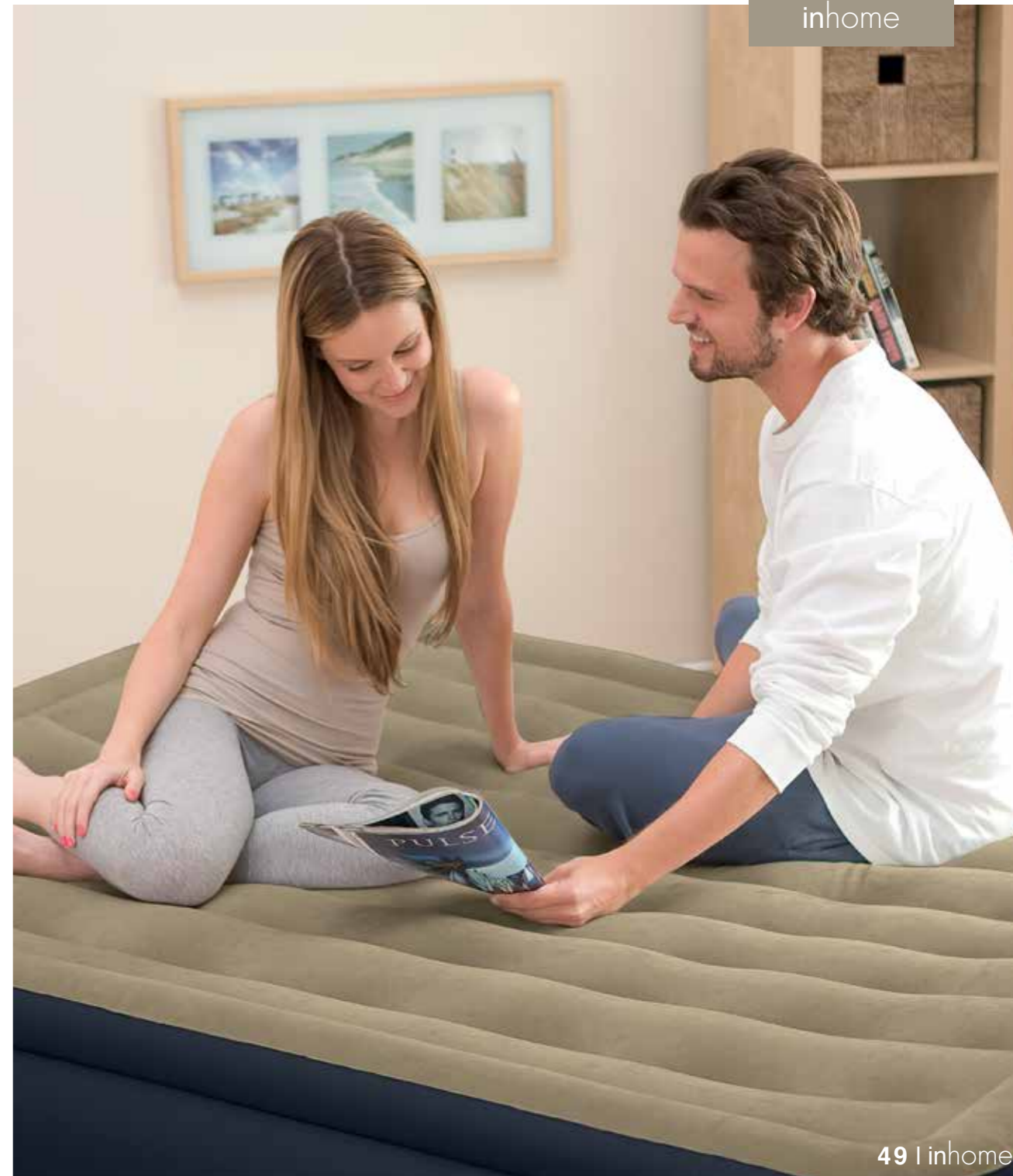
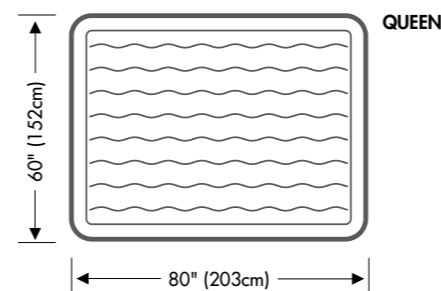



PREMIUM

Luxurious Comfort. Innovative Design.

Enjoy a luxurious night's sleep with an Intex Premium Airbed. Each airbed in our Premium line has been engineered and tested to provide you with a restful sleeping experience that rivals a traditional mattress. Plush Velvetaire™ flocking, interconnected air pocket system, luxurious foam – Intex Premium airbeds combine the best features with superior functionality that guarantee to provide you with the ultimate sleeping experience.



100% of our airbeds are quality tested to be air tight before they leave our factory.

ULTRA PLUSH BED

AIRBED WITH BUILT-IN ELECTRIC PUMP

Item	Size	Approximate Inflated Size	Built-in Pump	Case Pack	Case Weight
67951 / E 67952	Twin	39" x 75" x 18" (99cm x 191cm x 46cm)	110 - 120V 220 - 240V	2 Ea.	34.4 lb. (15.6kg)
66957 / E 66958	Queen	60" x 80" x 18" (152cm x 203cm x 46cm)	110 - 120V 220 - 240V	2 Ea.	51.2 lb. (23.3kg)



Double-Layered I-Beam Construction
U.S. Patent No. 6,568,011



Built-in AC Electric Pump

Here's an airbed that is sure to impress your most important guests: Intex's Ultra Plush Airbed. This raised bed combines comfort, convenience, and great appearance into one luxurious airbed, with its unique textured sleeping surface and inflated outer perimeter band for extra stability. Great for guests – but you might just want to keep it for family members!

ELEVATED WITH BUILT-IN ELECTRIC PUMP

- Quality tested 21.2 gauge (0.53mm) waterproof flocked top and sides with 15 gauge (0.38mm) vinyl bottom
- Flocked sleeping surface and sides for comfort and appearance
- Inflated bed fits standard sheets
- Bottom of the bed is contoured to provide extra gripping effect to increase stability
- Built-in electric pump for quick inflation and deflation
- Includes hand carry bag
- Shelf box



18"
(46cm)
BED HEIGHT

INFLATING TIMES*	
AC Electric Pump	
Twin	2½ minutes
Queen	4 minutes

* Inflating time varies by desired firmness

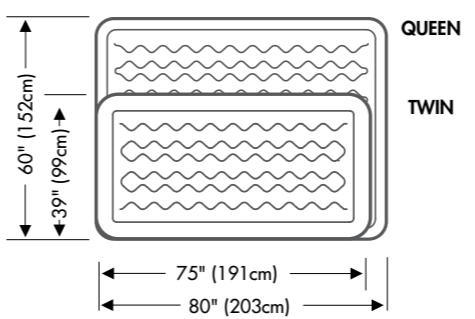

SUPREME AIR-FLOW BED

AIRBED WITH BUILT-IN ELECTRIC PUMP

Item	Size	Approximate Inflated Size	Built-in Pump	Case Pack	Case Weight
66963 / E 66964	Twin	39" x 75" x 20" (99cm x 191cm x 51cm)	110 - 120V 220 - 240V	2 Ea.	49.9 lb. (22.7kg)
66961 / E 66962	Queen	60" x 80" x 20" (152cm x 203cm x 51cm)	110 - 120V 220 - 240V	1 Ea.	35.4 lb. (16.1kg)



Coil-Beam/I-Beam Hybrid Construction
U.S. Patent No. 7,636,970



Built-in AC Electric Pump



20"
(51cm)
BED HEIGHT

INFLATING TIMES*

AC Electric Pump	
Twin	2½ minutes
Queen	4 minutes

* Inflating time varies by mattress size and desired firmness

Our top of the line Supreme Air Flow Bed is engineered to provide the ultimate comfort with the look and feel of a real high end bed! A network of inter-connected air pockets on the top and sides of the bed cause the air to flow smoothly and gradually across the sleeping surface for unbelievable comfort and stability. The dual chamber construction provides firm support and allows for fitted sheets to tuck in easily. Topped with super soft Velvetaire™ flocking, this bed rivals a traditional mattress, providing a premium sleeping experience.

ELEVATED WITH BUILT-IN ELECTRIC PUMP

- Quality tested 26.4 gauge (0.66mm) super soft Velvetaire™ flocked top and sides with 15 gauge (0.38mm) vinyl bottom
- Dual chamber construction consists of I-beams in bottom chamber and coil beams in upper chamber that is surrounded on top and sides with a layer of inter-connected air cells to ensure gradual, smooth airflow across the entire surface of the bed
- Mattress is raised 20" (51cm) from the floor for convenience
- Mattress quickly and easily inflates and deflates with a high-powered built-in electric pump
- Cozy flocked fabric mattress that allows for sheets to be easily tucked in
- Includes hand carry bag
- Shelf box

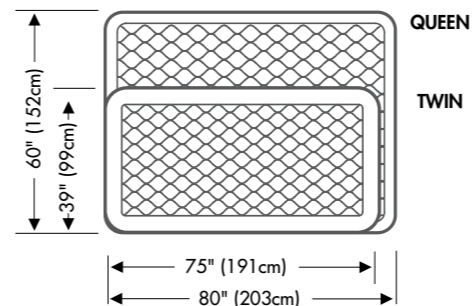

COMFORT FRAME BED

AIRBED WITH HAND-HELD AC PUMP

Item	Size	Approximate Inflated Size	Hand-Held Pump	Case Pack	Case Weight
67971 / E 67972	Queen	76" x 95" x 30" (193cm x 241cm x 76cm)	110 - 120V 220 - 240V	1 Ea.	39.1 lb. (17.8kg)



Hand-held AC Pump

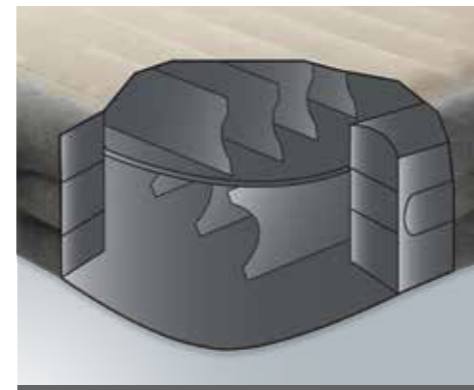

Enhanced I-Beam frame and bed construction



30" (76cm)
BED HEIGHT with backrest

INFLATING TIMES*	
AC Electric Pump	
Mattress	3½ minutes
Frame	1½ minutes

* Inflating time varies by desired firmness

The newly redesigned Comfort Frame Bed brings you a mattress comfortable enough to sleep on every night. The bed's new horizontal air chamber construction provides enhanced stability and comfort. The plush headboard provides additional support and keeps pillows away from the ground. The bed is covered in plush Velvetaire™ flocking for a luxurious sleeping surface. Bed sheets tuck easily and securely around the inner mattress which then slips into the inflated frame. This bed can also be converted into two separate beds by removing the inner mattress. Bed includes a hand-held electric pump and carry bag for added convenience and storage.

HEADBOARD FRAME BED WITH REMOVEABLE INNER MATTRESS FOR ADDED VERSATILITY

- Quality tested 26.4 gauge (0.66mm) super soft Velvetaire™ flocked top and sides with 15 gauge (0.38mm) vinyl bottom
- Mattress is raised 16½" (42cm) from the floor for convenience
- New horizontal chamber construction provides added stability and support
- Plush Velvetaire™ flocked sleeping surfaces
- Includes powerful hand-held electric pump
- Includes hand carry bag
- Folds compactly for storage or travel
- Shelf box

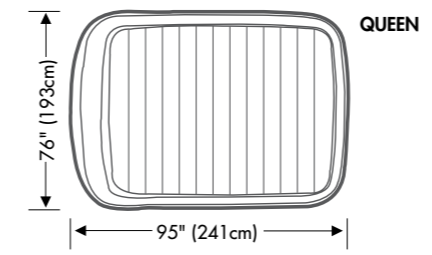

new!



FOAM TOP BED

AIRBED WITH BUILT-IN ELECTRIC PUMP

Item	Size	Approximate Inflated Size	Built-in Pump	Case Pack	Case Weight
67953 / E 67954	Queen	60" x 80" x 20" (152cm x 203cm x 51cm)	110 - 120V 220 - 240V	1 Ea.	30.2 lb. (13.7kg)

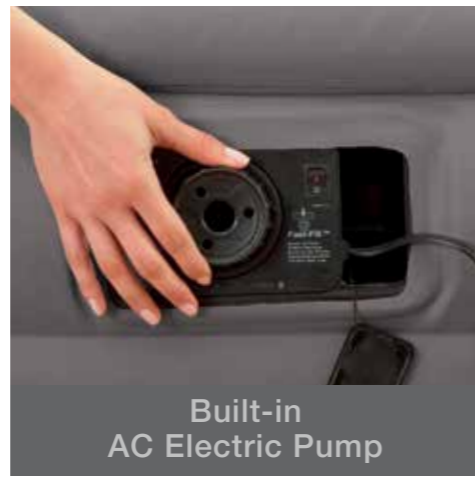

Built-in AC Electric Pump

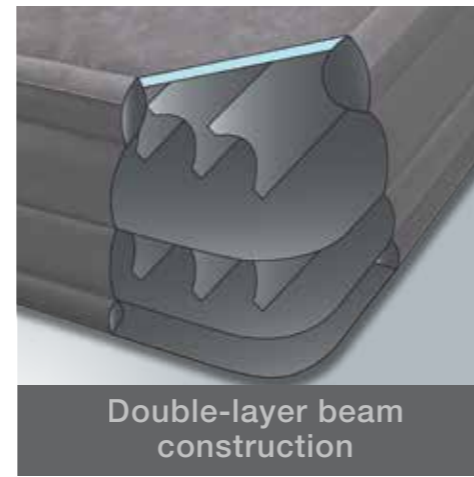

Double-layer beam construction



20"
(51cm)
BED HEIGHT

INFLATING TIMES*	
AC Electric Pump	
110-120V	4 minutes
220-240V	4 minutes

* Inflating time varies by desired firmness

Enjoy a luxurious night's sleep in our Foam Top High-Rise bed. Its foam sleeping surface comfortably contours to your body and provides added warmth for a rejuvenating sleep experience. The bed is covered in plush Velvetaire™ flocking that is soft to the touch and the bed's elevated height makes it easier to get in and out of, much like a traditional mattress. For fast and easy inflation & deflation the bed comes with a powerful built-in electric pump.

ELEVATED WITH BUILT-IN ELECTRIC PUMP

- Quality tested 26.4 gauge (0.66mm) super soft Velvetaire™ flocked top and sides with 15 gauge (0.38mm) vinyl bottom
- Foam Top layer
- Plush Velvetaire™ flocked sleeping surfaces
- Double layered I-beam construction
- Built-in electric pump
- Includes hand carry bag
- Folds compactly for storage or travel
- Shelf box

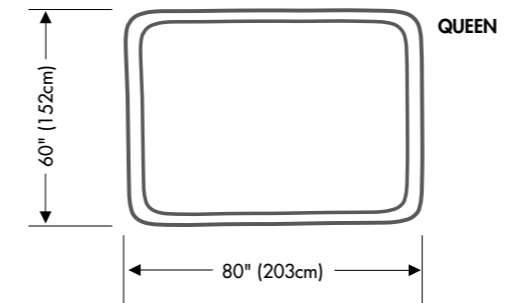

new!





AIR FURNITURE



Portable. Functional. Something For Everyone.

Intex brings to you an exciting and vibrant line of air furniture for any age, any setting and any season! With great colors and design, whether for the indoors or the outdoors, Intex has something for everyone. Decorate your room with Intex!

BEANLESS BAG CHAIR ASSORTMENT



A great bean bag without the hassle of beanbag inserts and slipcovers. Just unfold and inflate, and in minutes you have a super soft bean bag that is perfect for lounging, studying, or watching movies. Vivid colors will brighten up any room. Comes in an assortment of three bright and vivid colors: Magenta Pink, Lime Green, or Lilac Purple.

PERFECTLY PORTABLE BEANLESS BAG

- Quality tested 20.8 gauge (0.52mm) waterproof flocked top and sides with 15 gauge (0.38mm) vinyl bottom
- Available in magenta pink, lime green and lilac purple
- Folds compactly for storage
- Shelf box



Item	Approximate Inflated Size	Case Pack	Case Weight
68569NP / EP	42" x 41" x 27" (107cm x 104cm x 69cm)	6 Ea., Asst.	33.2 Lb. (15.1kg)



U.S. Patent No. 6,152,530, D441,205



Our plush Café Chair™ is the coolest seat in the house. With an innovative structure that gives you the comfort of a beanbag and the support of your favorite chair, the Café Chair™ is as comfortable as it is unique. Whether you are reading, watching TV, or relaxing, this is perfect! Comes in an assortment of three bright and vivid colors: Magenta Pink, Lime Green, or Lilac Purple.

FOR EXTENDED SEATING

- Quality tested 20.8 gauge (0.52mm) waterproof flocked top and sides with 15 gauge (0.38mm) vinyl bottom
- One large specially engineered seating cushion for serious pampering
- One small detachable backrest cushion for show and comfort
- Available in magenta pink, lime green and lilac purple
- Folds compactly for storage
- Shelf box



Item	Approximate Inflated Size	Case Pack	Case Weight
68563NP / EP	36" x 40" x 25½" (91cm x 102cm x 65cm)	3 Ea., Asst.	22.4 Lb. (10.2kg)

CAFÉ CHAIR™



CAFÉ CLUB CHAIR



Easy comfort in splash colors is the only way to describe our Café Club Chairs. Great for reading, gaming, or just chatting with friends, these chairs will bring life to any apartment or college dorm!

AN INVITING SPLASH OF COLOR AND COMFORT

- Quality tested 20.8 gauge (0.52mm) waterproof flocked top with 15 gauge (0.38mm) vinyl sides and bottom
- Available in magenta pink, lime green and sunny orange
- Folds compactly for storage
- Shelf box



Item	Approximate Inflated Size	Case Pack	Case Weight
68571NP / EP	38" x 30" x 27" (97cm x 76cm x 69cm)	3 Ea., Asst.	21.3 Lb. (9.7kg)



Stunning and eye-catching, this Café Chaise Chair adds flair to any room! Paired with an ottoman, the advanced structural design provides an exceptionally comfortable seat regardless of your height.

COLORFUL CUSHY LUXURY

- Quality tested 20.8 gauge (0.52mm) waterproof flocked top with 15 gauge (0.38mm) vinyl sides and bottom
- Combo valve has extra-wide openings for fast inflating and deflating
- Available in lilac purple, sky blue, and sunny orange
- Folds compactly for storage
- Shelf box



Item		Approximate Inflated Size	Case Pack	Case Weight
68572NP / EP	Chair	41" x 43" x 28" (104cm x 109cm x 71cm)	3 Ea., Asst.	20.9 Lb. (9.5kg)
	Ottoman	25" x 11" (64cm x 28cm)		



CAFÉ CHAISE CHAIR

BEANLESS BAG™ CHAIR



Intex completes the Beanless Bag™ Chair line with the introduction of a warm, neutral color combined with our revolutionary corduroy texture flocking! Its elegant and luxurious look and feel will add a new dimension to any room!

PERFECTLY PORTABLE BEANLESS BAG™

- Quality tested 26.4 gauge (0.66mm) waterproof flocked top and sides with 15 gauge (0.38mm) vinyl bottom
- Folds compactly for storage
- Shelf box



Item	Approximate Inflated Size	Case Pack	Case Weight
68579NP / EP	42" x 41" x 27" (107cm x 104cm x 69cm)	6 Ea.	34.9 Lb. (15.9kg)

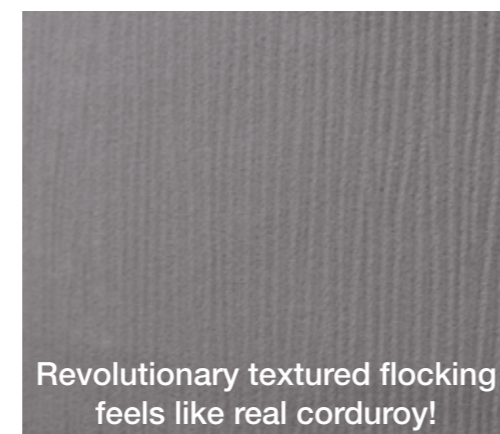

Revolutionary textured flocking feels like real corduroy!

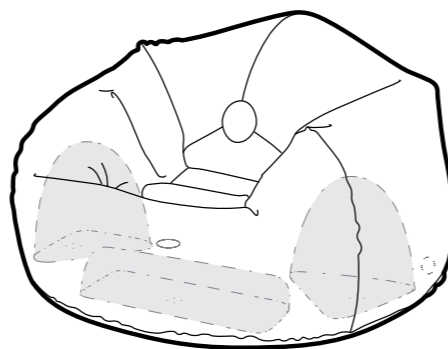

Beanless Bag™ chair inner structure
U.S. Patent No. 6,152,530, D441,205



Comfortable seating with slide cup holder

Attractive contours from any angle, the beauty of this lounge chair is matched only by its comfort. Contact surfaces on the top and sides are lined with flocking for the touch of luxury. The side cup holder is just as indispensable here as in your favorite sports car.



RELAX AT HOME WITH OUR ULTRA LOUNGE

- Quality tested 20.8 gauge (0.52mm) waterproof flocked top and sides with 15 gauge (0.38mm) vinyl bottom
- 2-in-1 valve has extra-wide openings for fast inflating and deflating
- Convenient cup holder for refreshments
- Folds compactly for storage
- Shelf box

Item	Approximate Inflated Size	Case Pack	Case Weight
68564NP / EP Chair	39" x 51" x 30" (99cm x 130cm x 76cm)	4 Ea.	30.2 Lb. (13.7kg)
Ottoman	25" x 11" (64cm x 28cm)		

ULTRA LOUNGE

new material!

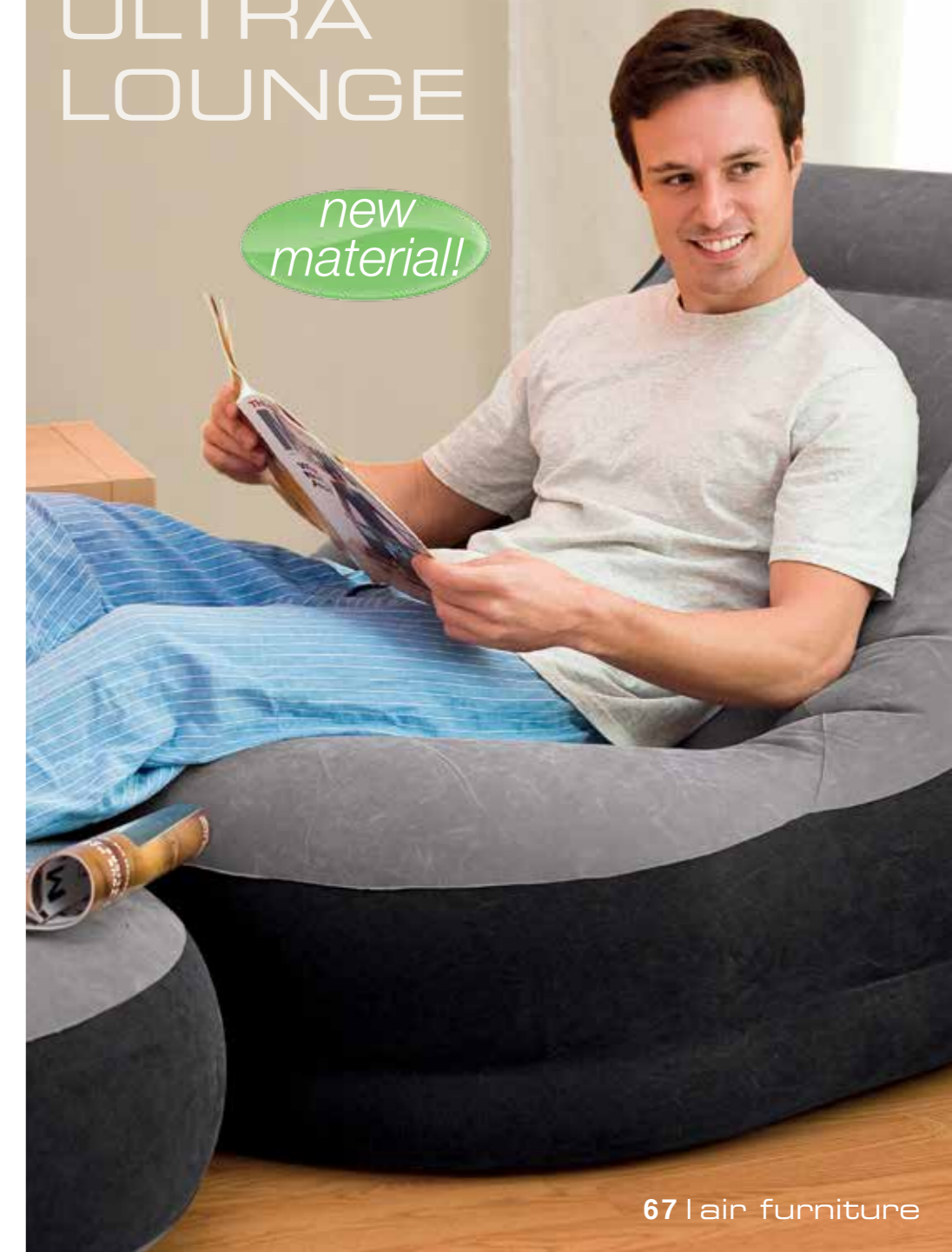

PULL-OUT CHAIR

new color!

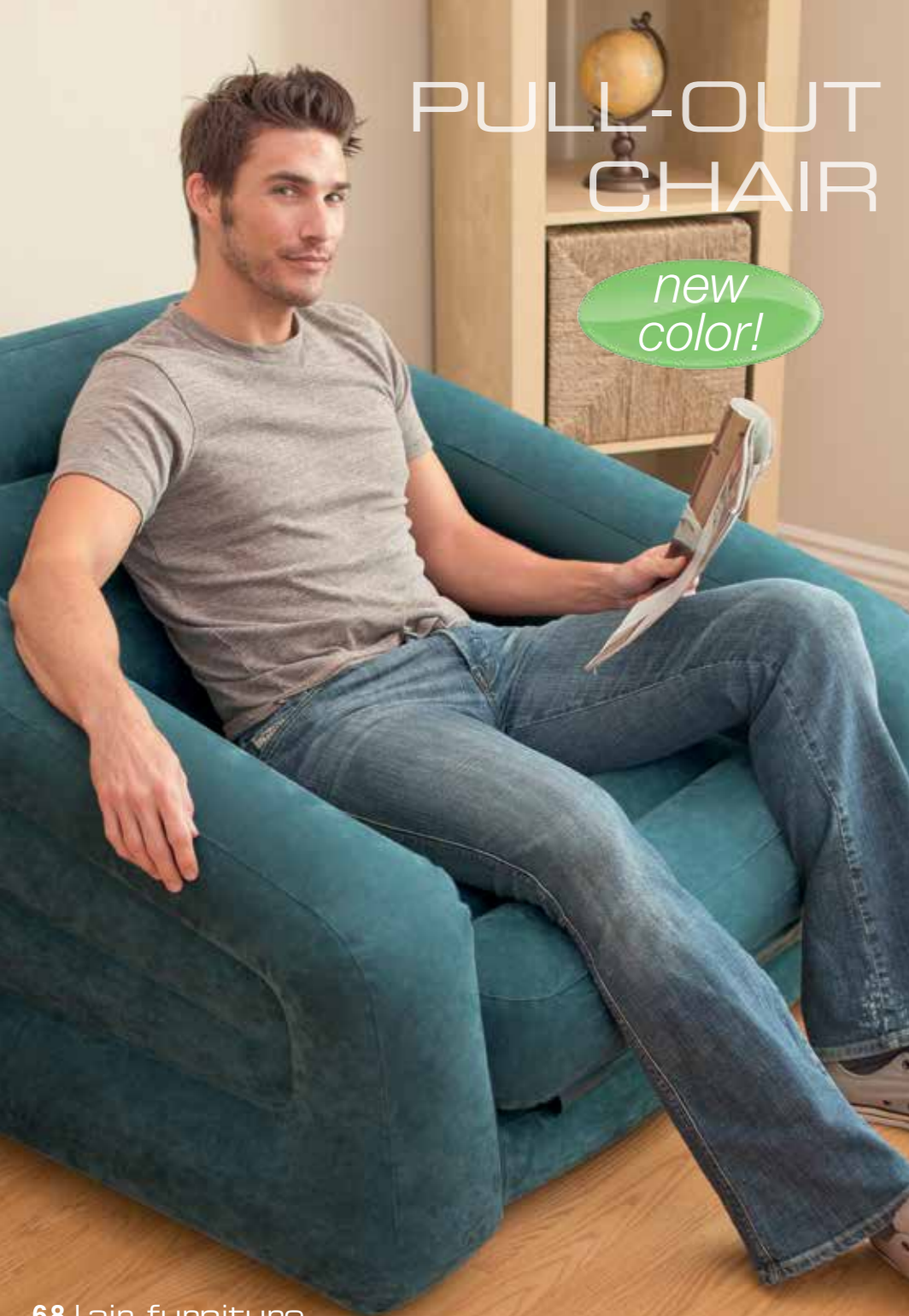

A perfect chair that transforms into a single bed! Not only is it comfortable, it's conveniently versatile. Ideal for college dorms, guest bedrooms and even on the road.

STURDY COMFORT

- Quality tested 20.8 gauge (0.52mm) waterproof flocked top and sides with 15 gauge (0.38mm) vinyl bottom
- 2-in-1 valve has extra-wide openings for fast inflating and deflating
- Folds compactly for storage
- Shelf box

Item	Approximate Inflated Size	Case Pack	Case Weight
68565NP / EP	43" x 86" x 26" (109cm x 218cm x 66cm)	2 Ea.	22.7 Lb. (10.3kg)

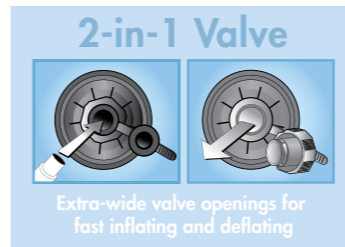
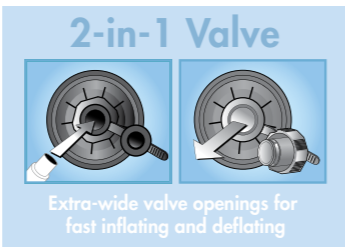

A versatile sofa that offers an affordable and comfortable sleeping solution for any home or even outdoor use. It is quick and easy to inflate and will seat or sleep two people.

PRACTICAL & VERSATILE

- Quality tested 20.8 gauge (0.52mm) waterproof flocked top and sides with 15 gauge (0.38mm) vinyl bottom
- 2-in-1 valve has extra-wide openings for fast inflating and deflating
- 2 quick inflation and deflation valves
- Comfortable backrest and armrest
- 2 cup holders
- Folds compactly for storage
- Shelf box

Item	Approximate Inflated Size	Case Pack	Case Weight
68566NP / EP	76" x 91" x 28" (193cm x 231cm x 71cm)	2 Ea.	43.1 Lb. (19.5kg)

new color!



PULL-OUT SOFA

EMPIRE CHAIR

new!



Modern, sophisticated and endlessly comfortable best describes this new addition to our line of inflatable chairs. In sunny orange, pink or lime green with an innovative transparent trim, this chair is the perfect combination of form and function. It's ideal for teens, college students and young professionals!

AN INVITING SPLASH OF COLOR AND COMFORT

- Quality tested 20.8 gauge (0.52mm) waterproof flocked top and sides with 20 gauge (0.50mm) laminated bottom
- Extra strong laminated bottom for better durability
- Great for both indoors and outdoors
- Shelf box

Item	Approximate Inflated Size	Color	Case Pack	Case Weight
68581NP / EP	44" x 43" x 27" (112cm x 109cm x 69cm)	Green	3 Ea.	21.5 Lb. (9.8kg)
68582NP / EP	44" x 43" x 27" (112cm x 109cm x 69cm)	3 Colors	3 Ea., Asst.	21.5 Lb. (9.8kg)



68581NP / EP

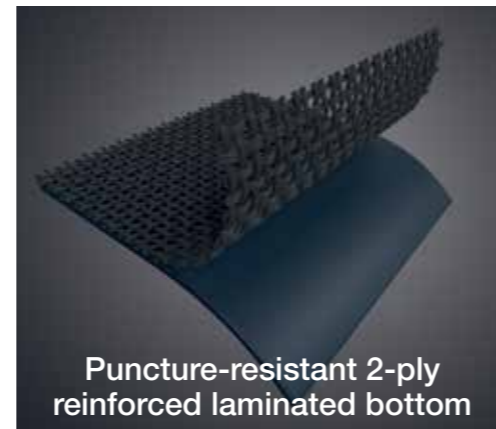

Puncture-resistant 2-ply reinforced laminated bottom



68582NP / EP



U.S. Patent No. 6,152,530, D441,205

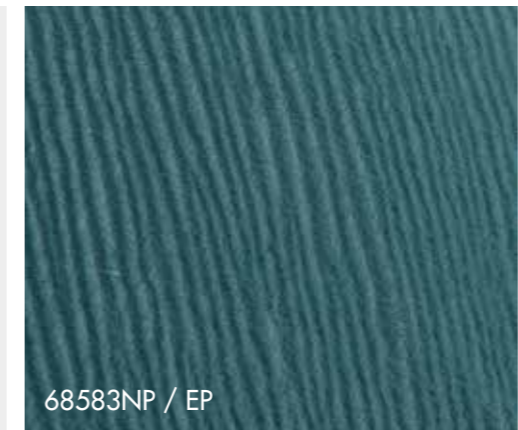

68583NP / EP



68584NP / EP

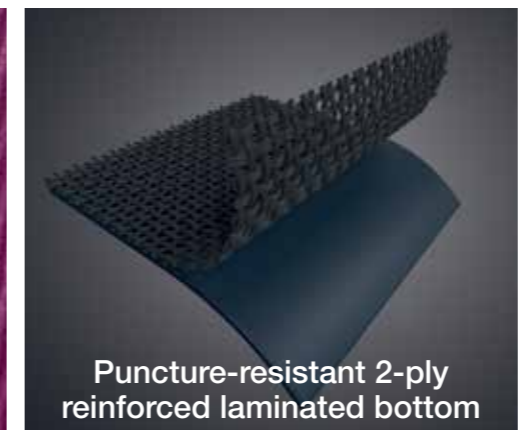

Puncture-resistant 2-ply reinforced laminated bottom

Taking our Beanless Bag™ Chair to the next level, this Deluxe version has a higher head rest and rich, velvety flocking reminiscent of cozy corduroy. The supportive and comfortable patented design is perfect for gaming, hanging out or just lazy down time. The reinforced bottom also makes this chair great for outdoor use on your patio, deck or lawn. Comes in sophisticated Classic Teal or Royal Grape.

COLORFUL CUSHY LUXURY

- Quality tested 26.4 gauge (0.66mm) waterproof flocked top and sides with 20 gauge (0.50mm) vinyl laminated bottom
- Extra strong laminated bottom for better durability
- Great for both indoors and outdoors
- Shelf box

Item	Approximate Inflated Size	Case Pack	Case Weight
68583NP / EP	48" x 50" x 32" (122cm x 127cm x 81cm)	4 Ea.	29.7 Lb. (13.5kg)
68584NP / EP	48" x 50" x 32" (122cm x 127cm x 81cm)	4 Ea.	29.7 Lb. (13.5kg)

air furniture

new!

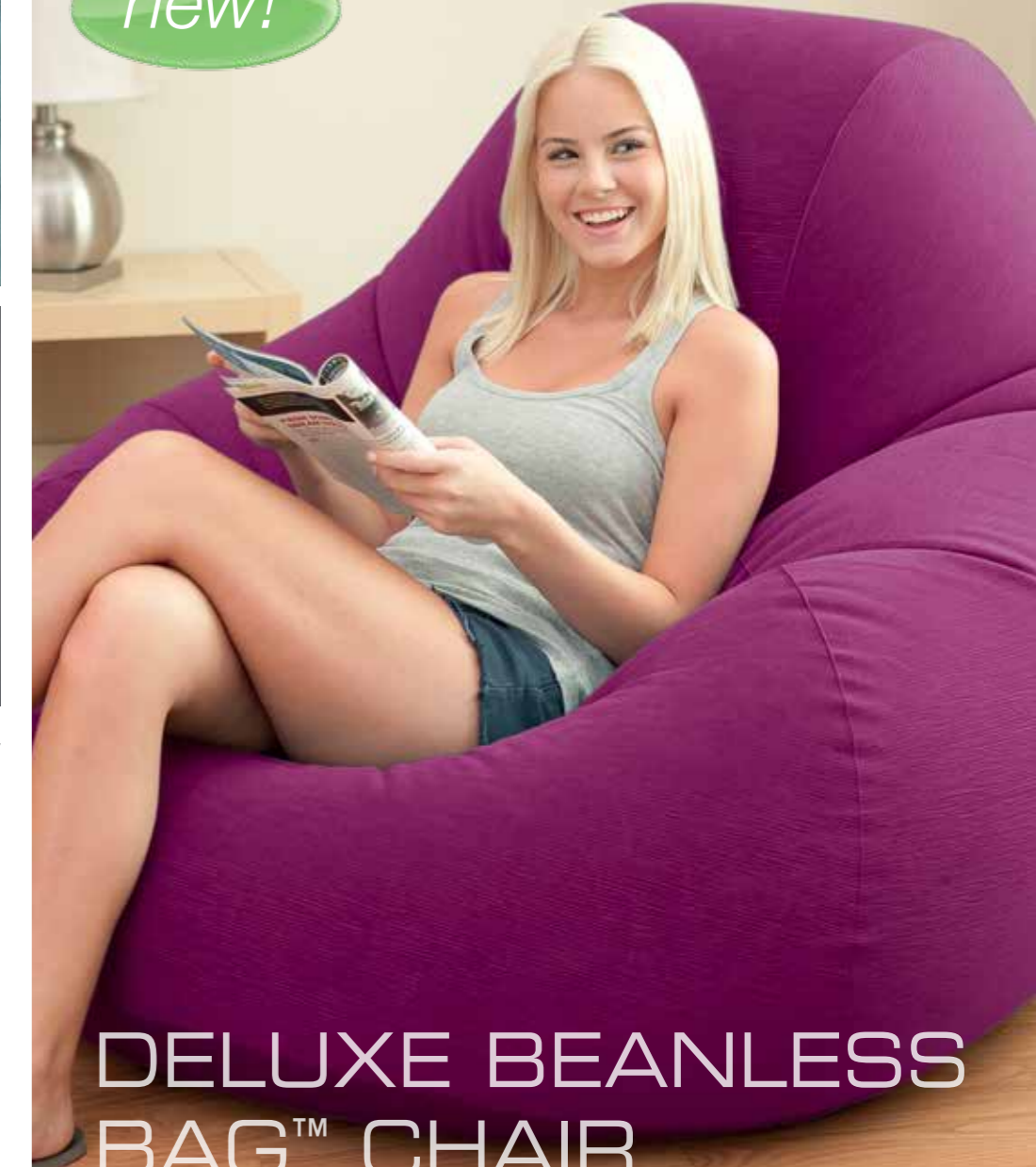

DELUXE BEANLESS BAG™ CHAIR

71 | air furniture

70 | air furniture

SPLASH LOUNGE

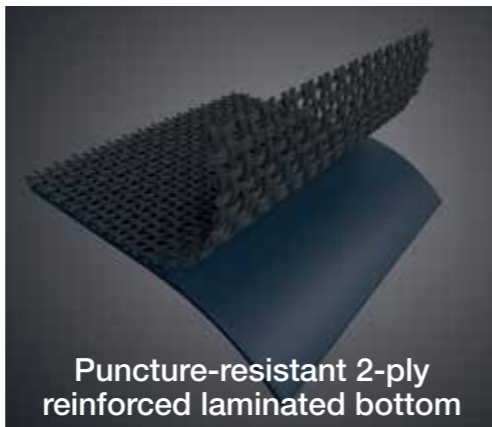

Puncture-resistant 2-ply reinforced laminated bottom

The Splash Lounge will look gorgeous indoors or outdoors. It's a great casual addition to any room. The reinforced bottom also makes it durable for lounging on the patio, yard or poolside.

PERFECTLY PORTABLE LOUNGE

- Quality tested 20.8 gauge (0.52mm) waterproof flocked top with 15 gauge (0.38mm) vinyl sides, 20 gauge (0.50mm) bottom
- Extra strong laminated bottom for better durability
- Great for both indoors and outdoors
- Shelf box

Item	Approximate Inflated Size	Case Pack	Case Weight
68880NP / EP	33" x 67" x 32" (84cm x 170cm x 81cm)	3 Ea.	20.8 Lb. (9.4kg)



new!

The Ultra Daybed Lounge invites you to relax, soak up the sun and hang out with friends. It's an elegant addition to any room, patio or yard as the reinforced bottom and soft flocking makes it versatile enough for both indoors and outdoors.

new!

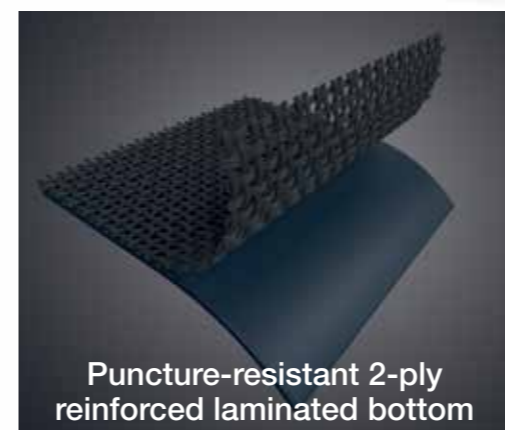

Puncture-resistant 2-ply reinforced laminated bottom

RELAX AT HOME WITH OUR ULTRA LOUNGE

- Quality tested 26.4 gauge (0.66mm) waterproof flocked top with 15 gauge (0.38mm) vinyl sides and 20 gauge (0.50mm) bottom
- Detachable backrest for extra comfort and versatility
- Extra strong laminated bottom for better durability
- Great for both indoors and outdoors
- Quick coupling buckles for the backrest
- Shelf box

Item	Approximate Inflated Size	Case Pack	Case Weight
68881NP / EP	75" (D.) x 21" (H.) (191cm x 53cm)	2 Ea.	33.8 Lb. (15.4kg)



air furniture

ULTRA DAYBED LOUNGE

73 | air furniture

72 | air furniture

JR. CAFÉ CLUB CHAIR

new!

Delight the little ones with this mini version of our hit Café Club Chair! They'll love being just like the grown ups in this version sized especially for them. Great for any child's bedroom or playroom in these pretty colors of Magenta, Lime Green and Sunny Orange.

AN INVITING SPLASH OF COLOR AND COMFORT

- Quality tested 20.8 gauge (0.52mm) waterproof flocked top with 15 gauge (0.38mm) vinyl sides and bottom
- Kid-sized chair just like the grown ups
- Pink, orange and green color assortment
- Shelf box



Item	Approximate Inflated Size	Case Pack	Case Weight
68597NP / EP	27" x 22" x 19" (69cm x 56cm x 48cm)	6 Ea., Asst.	19.0 Lb. (8.6kg)



The perfect airbed for kids with soft, inflatable pillows in three fun and exciting colors! It will come in handy for sleepovers, nap time and travel, without sacrificing comfort or convenience!

COZY & FUN

- Quality tested 20.8 gauge (0.52mm) waterproof flocked top with 12 gauge (0.30mm) vinyl sides and bottom
- Assorted bright, fun colors
- Soft flocking for extra comfort
- Includes inflatable flocked pillow
- Repair patch
- Shelf box



Item	Approximate Inflated Size	Case Pack	Case Weight
66801NP / EP	34½" x 62" x 7" (88cm x 157cm x 18cm)	6 Ea., Asst.	27.5 Lb. (12.5kg)

air furniture

COZY KIDZ™ AIRBED





KIDZ TRAVEL BED SET

Excellent solution to sleep comfortably when away from home. Perfect for trips, sleepovers, camping and even for nap times!

QUICK & EASY SOLUTION

- Includes hand pump
- Inner mattress size: 27" x 52" x 4" (69cm x 132cm x 10cm)
- Uses standard crib sheets
- Inflates and deflates quickly
- Includes carry bag
- Shelf box



Item	Approximate Inflated Size	Hand Pump	Case Pack	Case Weight
66810NP / EP	42" x 66" x 10" (107cm x 168cm x 25cm)	68612	3 Ea.	29.3 Lb. (13.3kg)

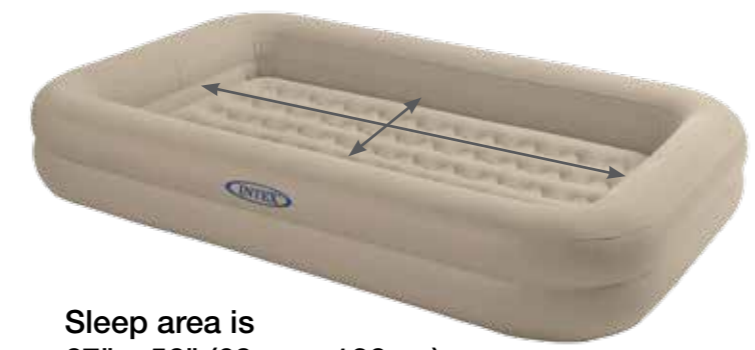

Sleep area is
27" x 52" (69cm x 132cm)
with soft frame surround



TAKE ALONG BED



Our redesigned Take Along Bed provides the perfect mattress for sleepovers and college dorms. The bed's new horizontal air chamber construction provides added stability and support around the entire bed. The plush flocked sleeping surface and built-in pillow provide extra comfort for a restful night's sleep. Bed includes a pump and carry bag for convenience and instant comfort on the go.

TAKE ALONG BED

- Quality tested 21.2 gauge (0.53mm) waterproof flocked top with 15 gauge (0.38mm) vinyl sides and bottom
- Built-in pillow
- Plush flocked sleeping surface
- Double layered horizontal I-beam construction
- Mattress is raised 14" (36cm) from the floor for convenience
- AC electric pump
- Includes hand carry bag
- Folds compactly for storage or travel
- Shelf box

INFLATING TIMES*	
AC Electric Pump	
110-120V	1½ minutes
220-240V	1½ minutes

* Inflating time varies by mattress size and desired firmness

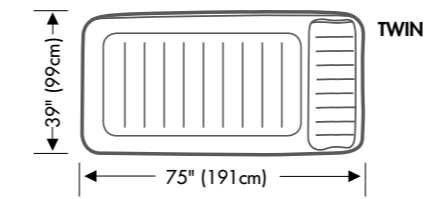
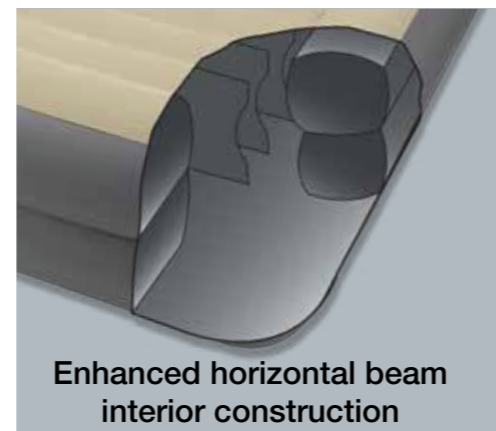

Item	Approximate Inflated Size	Hand-Held Pump	Case Pack	Case Weight
67775NP/EP	39" x 75" x 18½"	110-120V	2 Ea.	27.0 Lb. (12.2kg)
67776NP	(99cm x 191cm x 47cm)	220-240V		



new!

air furniture

ACCESSORIES

PILLOWS

#68671 / E
Fabric Camping Pillow
 • 17" x 11" x 3½" (43cm x 28cm x 9cm)
 • Comfortable I-beam construction
 • Pegable box
 24 Ea., 9.7 Lb. (4.4kg)



#68671

#68672 / E
Downy Pillow
 • 17" x 11" x 3½" (43cm x 28cm x 9cm)
 • Waterproof flocked top
 • I-beam construction
 • Pegable box
 24 Ea., 10.4 Lb. (4.7kg)



#68672



#68675

#68675 / E
Travel Pillow
 • 13" x 10" x 3" (33cm x 25cm x 8cm)
 • Black super soft Velvetaire™ flocked surface
 • Perfect for those long plane and car trips
 • Contoured for neck support
 • Folds up for easy travel
 • Pegable box
 36 Ea., 7.6 Lb. (3.5kg)



#68676NP / EP
Kidz Pillows
 • 17" x 11" x 3½" (43cm x 28cm x 9cm)
 • Available in Sky Blue, Magenta Pink, and Lime Green
 • Pegable box
 24 Ea., Asst. 10.4 Lb. (4.7kg)



#68676

#68677 / E
Ultra-Comfort Pillow
 • 24" x 12" x 4" (61cm x 30cm x 10cm)
 • Comfortable I-beam construction
 • Pegable box
 12 Ea., 11.4 Lb. (5.2kg)



#68677



LED LIGHT



#68690 / E
5-in-1 LED Light
 • Optics design with 10x zoom lens
 • 360 degree beacon
 • Built-in easy access battery cartridge
 • Two additional battery holders in a convenient carry pack
 • Durable water resistant and impact resistant construction
 • Multiple patents pending
 • Shelf box
 6 Ea., 8.5 Lb. (3.9kg)



FUNCTION

OPERATION

Flashlight

Choose between three power levels (8%, 50%, 100%) plus adjustable focus to meet all flashlight needs.

Hanging Lantern

Choose between three power levels to operate in floodlight mode with lantern suspended.

Table Top Lantern

Select lantern mode: 8% power level is perfect for a nightlight, while 50% and 100% levels are ideal to light up rooms, garages, RVs, or tents.

Hazard Light

Flashes an amber-colored warning light. A must-have for car & boat owners, campers, and other travelers.

Emergency Beacon

At full power, the international SOS signal autoflashes at up to a full kilometer, easily recognizable by rescue personnel.

Operates on 3 AAA batteries (not included) and comes with 2 extra battery holders that can be quickly inserted for immediate use.



#68691 / E
Deluxe 5-in-1 LED Light
 • Built-in lithium-iron rechargeable battery
 • Optics design with 10x zoom lens
 • 360 degree beacon
 • USB charger cable
 • 12V charger cable
 • External power pack
 • Durable water resistant and impact resistant construction
 • Multiple patents pending
 • Shelf box
 6 Ea., 12.6Lb. (5.7kg)

Multiple power sources assure you never run out of power options.



12 volt charger cable



USB charger cable



External power pack

ACCESSORIES

ELECTRIC PUMPS

These Quick-Fill™ electric pumps have a sleek, aerodynamic design that fits perfectly in the palm of your hand, yet still inflate even the largest of inflatables in a breeze.



Quick-Fill™ BATTERY Pump features include:

- 24% more air flow than previous version (#68639)
- Operates on 6 C-cell size batteries
- 3 interconnecting nozzles
- CE approved
- Shelf box

#68638



Quick-Fill™ DC Electric Pump features include:

- 3 interconnecting nozzles
- Plug into 12V DC automobile cigarette lighter or 12V DC accessory outlet
- ETL approved
- CE, GS approved
- Shelf box

#66626 (12V)



Quick-Fill™ AC Electric Pump features include:

- 3 interconnecting nozzles
- Thermo protector incorporated for safety
- ETL approved (110 – 120V)
- CE, GS approved (220 – 240V)
- Shelf box

#66619 (110-120V)
#66620 (220-240V)

Quick-Fill™ AC Electric Pump features include:

- 3 interconnecting nozzles with hose
- Thermo protector incorporated for safety
- New shape with easy carry handle
- ETL approved (110-120V model)
- CE, GS approved (220-240V model)
- Shelf box



#66623 (110-120V)
#66624 (220-240V)

Quick-Fill™ High PSI Indoor/outdoor Electric Pump features include:

- 3 interconnecting nozzles with hose
- For both indoor and outdoor use - plugs into cigarette lighter or household electrical outlet
- 2-speed switch
- Inflates athletic balls up to 12 psi
- Detachable DC cigarette cord
- ETL approved (110-120V)
- CE, GS approved (220-240V)
- Shelf box



#68608 (110-120V)
#68609 (220-240V)

Quick-Fill™ RECHARGEABLE Pump features include:

- 3 interconnecting nozzles
- A 12V DC power adapter for vehicle charging and a household AC power adapter for home charging
- 12V DC to inflate and deflate while recharging
- Automatic over-charge cut off for safety protection
- New shape with easy carry handle
- ETL approved (110 – 120V)
- CE approved (220 – 240V)
- Shelf box



#66621 (110-120V)
#66622 (220-240V)

new!



#66631 (110-120V)
#66632 (220-240V)

Quick-Fill™ AC/DC Electric Pump features include:

- 3 interconnecting nozzles
- 12V DC & AC power adapter for easy Outdoor and Indoor use
- ETL approved (110 – 120V)
- CE approved (220 – 240V)
- Shelf box

MANUAL PUMPS



#68612 / E Double Quick I Hand Pump

- 11½" (29cm)
- 3 interconnecting nozzles with hose
- TUV RL approved
- Inflates on both up and down strokes
- Shelf box

#68612

12 Ea., 11.0 Lb. (5.0kg)



#68614 / E Double Quick II Hand Pump

- 2 times the air flow of #68612
- 14" (36cm)
- 3 interconnecting nozzles with hose
- TUV RL approved
- Inflates on both up and down strokes
- Shelf box

#68614

4 Ea., 6.1 Lb. (2.8kg)



#68605 / E Double Quick III S Hand Pump

- 3 times the air flow of #68612
- 14½" (37cm)
- 3 interconnecting nozzles with hoses
- TUV RL approved
- Inflates and deflates
- Pumps on up and down strokes
- Shelf box

#68605

3 Ea., 6.4 Lb. (2.9kg)



#68615 / E Double Quick III Hand Pump

- 3½ times the air flow of #68612
- 19" (48cm)
- TUV RL approved
- Large nozzle threaded for athletic ball inflating needle (one included)
- Inflates athletic balls up to 8 psi
- Inflates and deflates
- Pumps on up and down strokes
- Shelf box

#68615

3 Ea., 8.9 Lb. (4.0kg)
U.S. Patent No. 6,299,420

#68610 / E Giant Bellows Foot Pump

- 50% more air flow than of #69611
- 12" (30cm)
- TUV RL approved
- Inflates and deflates
- Shelf box

#68610



#69611 / E Bellows Foot Pump

- 11" (28cm)
- TUV RL approved
- Inflates and deflates
- Shrink wrapped with litho label

6 Ea., 8.4 Lb. (3.8kg)



#69611

#69613 / E Double Quick Mini Hand Pump

- 11½" (29cm)
- TUV RL approved
- Inflates on fore and back strokes
- Hose with graduated nozzle



#69613

Item #	Voltage			Disposable Batteries	Outdoor Use	Accordion Hose with 3 Nozzles	3 Interconnecting Nozzles	Max. Air Flow (L/min)	Case Pack	Weight Lb (kg)
	110-120 AC	220-240 AC	12 DC							
66631 / E	•		•				•	≥450 (15.9CFM)	6	13.0 (5.9)
66632		•	•				•	≥450 (15.9CFM)	6	13.0 (5.9)
68638 / E				6 x C	•		•	≥380 (13.4CFM)	6	6.0 (2.7)
66626 / E			•		•		•	≥600 (21.2CFM)	6	8.8 (4.0)
66619 / E	•				•		•	≥600 (21.2CFM)	6	8.8 (4.0)
66620		•			•		•	≥600 (21.2CFM)	6	8.8 (4.0)
66623 / E	•				•		•	≥1100 (38.9CFM)	4	11.1 (5.1)
66624		•			•		•	≥1100 (38.9CFM)	4	11.1 (5.1)
68608 / E	•		•		•		•	≥400 (14.1CFM)	4	30.1 (13.7)
68609		•	•		•		•	≥400 (14.1CFM)	4	30.1 (13.7)
66621 / E	•		•		•		•	≥600 (21.2CFM)	4	10.8 (4.9)
66622		•	•		•		•	≥600 (21.2CFM)	4	11.1 (5.1)

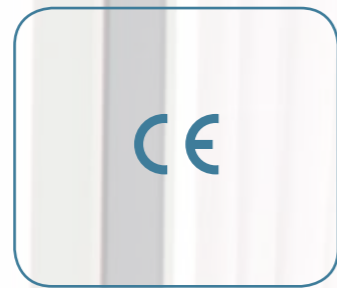
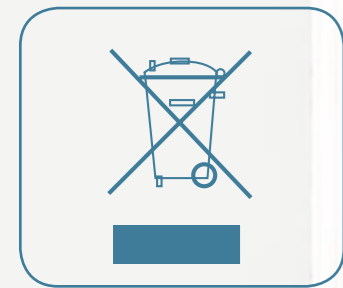

COMMITMENT TO EXCELLENCE

In today's rapidly evolving and highly competitive environment, this translates into a total commitment to product quality, including conformity to all relevant safety & quality regulations and standards. Examples include:

- Regulation (EC) No.1907/2006 "Registration, Evaluation, Authorisation and Restriction of Chemicals (REACH)"
- EN 71 "Safety of toys" (European standard)
- EN 13138 "Buoyant aids for swimming instruction" (European standard)
- EN15649 "Floating leisure articles for use on and in the water" (European standard for airmats, lounges and other similar items)
- EN 60335-2-41 "Safety of household and similar electrical appliances, particular requirements for pumps" (European standard for water pumps)
- ISO 6185-1 "Inflatable boats" (International standard for Sports Boats)
- NMMA-ABYC (USA standard for hi-end sports boats)
- ASTM F963 "Standard Consumer Safety Specification for Toy Safety" (USA toy standard)
- ANSI/APSP-4 "AGP standard" (USA standard for above ground pools)
- CPSIA "Consumer Product Safety Improvement Act" (USA regulation of consumer and children's products)
- ASTM F2666 "Small pools standard" (USA standard for pools under 36" water depth)
- UL1450 "Electric inflators" (USA standard for electric inflators)
- UL1081 "Swimming pool pumps, filters and chlorinators" (USA standard)
- UL1563 "Electric Spas" (USA standard for Spa)

Intex's commitment to Excellence extends to helping our environment and supporting the ecosystem. It begins with product design. Intex's filter pumps operate on much lower amps than most filter pumps in the market, reducing electricity consumption. Our saltwater systems clean pools using only natural salt, eliminating the ongoing need for environmentally unfriendly packaged chlorine.

Intex also operates one of the most comprehensive recycling programs in the industry. We are the first company in China to successfully obtain a license to ship consumers' returns in the original package back to China to be recycled. Therefore, used materials and product returns are prevented from going to landfills and instead re-used in the manufacturing process where up to 10% of annually produced PVC is recycled.

Intex designs all of our own packaging for our products. We constantly challenge our methods of packaging to improve efficiency and reduce waste. More compact packaging techniques save cardboard while cutting down on space utilization, saving freight and fuel consumption.

As a manufacturer, Intex knows it has a responsibility to manage the amount of waste produced. As an employer of over ten thousand people, we also encourage our own employees to recycle, reduce waste, and be conscious of the environment. Starting from recycling corners for all our worldwide office facilities, our Factory has worked with the local government as well as through sponsorships with key partners to strengthen our efforts to be more eco-friendly. Intex has worked to provide incentives and seminars to employees as well as setting targets to reduce energy consumption. In addition, Intex has made significant investment in technology to achieve these goals. For example, we have implemented a frequency converter system which converts diesel to natural gas, installed solar water heaters and set up a recycled sewage system, and invested in equipment that reduces gas emissions.

From product design, to more efficient processes that save energy and reduce waste, to a world class recycling program, to more energy efficient offices, the people at Intex are striving to provide the best value products anywhere while constantly keeping our global ecosystem in mind.





ROLL 'N GO™ BED **68711**

AIRBED WITH HAND PUMP			
Item	Size	Approximate Inflated Size	Hand Pump
68711/E	JR. Twin	30" x 75" x 6" (76cm x 191cm x 15cm)	68612

new! 68711
P.08-09



COMFORT-PLUSH ELEVATED AIRBED **64411**

AIRBED WITH BUILT-IN ELECTRIC PUMP			
Item	Size	Approximate Inflated Size	Built-in Pump
64411/E	Twin	39" x 75" x 18" (99cm x 191cm x 46cm)	110 - 120V 220 - 240V
64413/E	Queen	60" x 80" x 18" (152cm x 203cm x 46cm)	110 - 120V 220 - 240V

new! 64411
P.14-15



CAMPING MATS **68797**

CAMPING MAT	
Item	Approximate Inflated Size
68797/E	72½" x 26½" x 6¾" (184cm x 67cm x 17cm)
68798/E	74½" x 28½" x 8" (189cm x 72cm x 20cm)
68799/E	76" x 50" x 9¼" (193cm x 127cm x 24cm)

68797
P.22



AIRBED ONLY		CLASSIC DOWNY BED	
Item	Size	Approximate Inflated Size	
68950/E	JR. Twin	30" x 75" x 8¾" (76cm x 191cm x 22cm)	
68757/E	Twin	39" x 75" x 8¾" (99cm x 191cm x 22cm)	
68758/E	Full	54" x 75" x 8¾" (137cm x 191cm x 22cm)	
68759/E	Queen	60" x 80" x 8¾" (152cm x 203cm x 22cm)	
68755/E	King	72" x 80" x 8¾" (183cm x 203cm x 22cm)	
AIRBED SET Includes two I-beam pillows 17" x 11" x 3½" (43cm x 28cm x 9cm) and a #68612 Double-Quick air pump			
Item	Size	Approximate Inflated Size	Hand Pump
68765/E	Queen	60" x 80" x 8¾" (152cm x 203cm x 22cm)	68612

68950
P.26-27



PILLOW REST MID-RISE BED **67741**

AIRBED WITH BUILT-IN ELECTRIC PUMP			
Item	Size	Approximate Inflated Size	Built-in Pump
67741/E	Twin	39" x 75" x 15" (99cm x 191cm x 38cm)	110 - 120V 220 - 240V
67742	Queen	60" x 80" x 15" (152cm x 203cm x 38cm)	110 - 120V 220 - 240V

67741
P.34-35



PILLOW REST RAISED BED **67713**

AIRBED WITH BUILT-IN ELECTRIC PUMP			
Item	Size	Approximate Inflated Size	Built-in Pump
67713/E	Queen	60" x 80" x 18½" (152cm x 203cm x 47cm)	110 - 120V 220 - 240V

67713
P.42-43

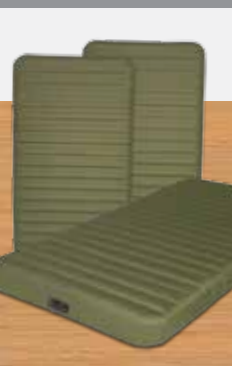

SUPER-TOUGH™ AIRBED **68725**

AIRBED ONLY			
Item	Size	Approximate Inflated Size	
68725/E	JR. Twin	30" x 75" x 6" (76cm x 191cm x 15cm)	

AIRBED WITH BELLOWS FOOT PUMP			
Item	Size	Approximate Inflated Size	
68726/E	Twin	39" x 75" x 8" (99cm x 191cm x 20cm)	

AIRBED WITH BUILT-IN RECHARGEABLE BATTERY PUMP			
Item	Size	Approximate Inflated Size	
68727/E	Twin	39" x 75" x 8" (99cm x 191cm x 15cm)	

68725
P.10-11

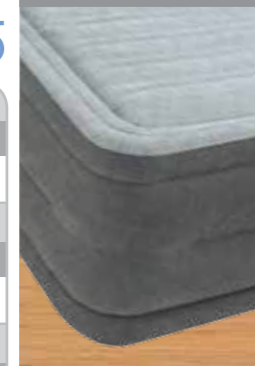

COMFORT-PLUSH HIGH RISE AIRBED **64417**

AIRBED WITH BUILT-IN ELECTRIC PUMP			
Item	Size	Approximate Inflated Size	Built-in Pump
64417/E	Queen	60" x 80" x 22" (152cm x 203cm x 56cm)	110 - 120V 220 - 240V

new! 64417
P.16-17



DOWNY BED **66950**

AIRBED WITH BUILT-IN FOOT PUMP			
Item	Size	Approximate Inflated Size	
66950/E	JR. Twin	30" x 75" x 8¾" (76cm x 191cm x 22cm)	
66927/E	Twin	39" x 75" x 8¾" (99cm x 191cm x 22cm)	
66928/E	Full	54" x 75" x 8¾" (137cm x 191cm x 22cm)	
66929/E	Queen	60" x 80" x 8¾" (152cm x 203cm x 22cm)	

66950
P.23



2-IN-1 BED **67743**

AIRBED ONLY		
Item	Size	Approximate Inflated Size
67743/E	Twin	39" x 75" x 18" (99cm x 191cm x 46cm)
67744/E	Queen	60" x 80" x 18" (152cm x 203cm x 46cm)

67743
P.30-31



DELUXE MID RISE PILLOW REST **67725**

AIRBED WITH HAND-HELD AC PUMP			
Item	Size	Approximate Inflated Size	Hand-held Pump
67725/E	Queen	60" x 80" x 16" (152cm x 203cm x 41cm)	110 - 120V 220 - 240V
67726	Queen	60" x 80" x 16" (152cm x 203cm x 41cm)	110 - 120V 220 - 240V

67725
P.36-37



DELUXE PILLOW REST RAISED BED **67730**

AIRBED ONLY		
Item	Size	Approximate Inflated Size
67730/E	Queen	60" x 80" x 19" (152cm x 203cm x 48cm)

AIRBED WITH BUILT-IN ELECTRIC PUMP			
Item	Size	Approximate Inflated Size	Built-in Pump
67731/E	Twin	39" x 75" x 19" (99cm x 191cm x 48cm)	110 - 120V 220 - 240V
67732	Queen	60" x 80" x 19" (152cm x 203cm x 48cm)	110 - 120V 220 - 240V
67737/E	Queen	60" x 80" x 19" (152cm x 203cm x 48cm)	110 - 120V 220 - 240V
67738	Queen	60" x 80" x 19" (152cm x 203cm x 48cm)	110 - 120V 220 - 240V

67736
P.44-45



COMFORT-PLUSH MID RISE AIRBED **67765**

AIRBED WITH BUILT-IN ELECTRIC PUMP			
Item	Size	Approximate Inflated Size	Built-in Pump
67765/E	Twin	39" x 75" x 13" (99cm x 191cm x 33cm)	110 - 120V 220 - 240V
67766	Twin	39" x 75" x 13" (99cm x 191cm x 33cm)	110 - 120V 220 - 240V
67767/E	Full	54" x 75" x 13" (137cm x 191cm x 33cm)	110 - 120V 220 - 240V
67768	Full	54" x 75" x 13" (137cm x 191cm x 33cm)	110 - 120V 220 - 240V
67769/E	Queen	60" x 80" x 13" (152cm x 203cm x 33cm)	110 - 120V 220 - 240V
67770	Queen	60" x 80" x 13" (152cm x 203cm x 33cm)	110 - 120V 220 - 240V

new color! 67765
P.12-13



PREMIUM COMFORT AIRBED **64403**

AIRBED WITH BUILT-IN ELECTRIC PUMP			
Item	Size	Approximate Inflated Size	Built-in Pump
64403/E	Queen	60" x 80" x 16" (152cm x 203cm x 41cm)	110 - 120V 220 - 240V
64404	Queen	60" x 80" x 16" (152cm x 203cm x 41cm)	110 - 120V 220 - 240V
64407/E	Queen	60" x 80" x 20" (152cm x 203cm x 51cm)	110 - 120V 220 - 240V
64408	Queen	60" x 80" x 20" (152cm x 203cm x 51cm)	110 - 120V 220 - 240V

new! 64403
P.18-19



PRESTIGE DOWNY BED **66967**

AIRBED WITH SEPARATE BATTERY PUMP (6 X C-CELL)			
Item	Size	Approximate Inflated Size	
66967/E	Twin	39" x 75" x 8¾" (99cm x 191cm x 22cm)	
66968/E	Full	54" x 75" x 8¾" (137cm x 191cm x 22cm)	
66969/E	Queen	60" x 80" x 8¾" (152cm x 203cm x 22cm)	

66967
P.24-25



AIRBED ONLY		PILLOW REST CLASSIC BED	
Item	Size	Approximate Inflated Size	
66767/E	Twin	39" x 75" x 12" (99cm x 191cm x 30cm)	
66768/E	Full	54" x 75" x 12" (137cm x 191cm x 30cm)	
66769/E	Queen	60" x 80" x 12" (152cm x 203cm x 30cm)	
66770/E	King	72" x 80" x 12" (183cm x 203cm x 30cm)	
AIRBED WITH BUILT-IN ELECTRIC PUMP			
Item	Size	Approximate Inflated Size	Built-in Pump
66775/E	Twin	39" x 75" x 12" (99cm x 191cm x 30cm)	110 - 120V 220 - 240V
66779	Twin	39" x 75" x 12" (99cm x 191cm x 30cm)	110 - 120V 220 - 240V
66776/E	Full	54" x 75" x 12" (137cm x 191cm x 30cm)	110 - 120V 220 - 240V
66780	Full	54" x 75" x 12" (137cm x 191cm x 30cm)	110 - 120V 220 - 240V
66777/E	Queen	60" x 80" x 12" (152cm x 203cm x 30cm)	110 - 120V 220 - 240V
66781	Queen	60" x 80" x 12" (152cm x 203cm x 30cm)	110 - 120V 220 - 240V

66767
P.32-33



PILLOW REST RAISED BED **66721**

AIRBED ONLY			
Item	Size	Approximate Inflated Size	
66721/E	Twin	39" x 75" x 18½" (99cm x 191cm x 47cm)	
66720/E	Queen	60" x 80" x 18½" (152cm x 203cm x 47cm)	

AIRBED WITH BUILT-IN ELECTRIC PUMP			
Item	Size	Approximate Inflated Size	Built-in Pump
66705/E	Twin	39" x 75" x 18½" (99cm x 191cm x 47cm)	110 - 120V 220 - 240V
66706	Twin	39" x 75" x 18½" (99cm x 191cm x 47cm)	110 - 120V 220 - 240V
67701/E	Queen	60" x 80" x 18½" (152cm x 203cm x 47cm)	110 - 120V 220 - 240V
66702	Queen	60" x 80" x 18½" (152cm x 203cm x 47cm)	110 - 120V 220 - 240V

66721
P.40-41



RAISED DOWNY BED **66717**

AIRBED WITH BUILT-IN ELECTRIC PUMP			
Item	Size	Approximate Inflated Size	Built-in Pump
66717/E	Queen	60" x 80" x 22" (152cm x 203cm x 56cm)	110 - 120V 220 - 240V
66718	Queen	60" x 80" x 22" (152cm x 203cm x 56cm)	110 - 120V 220 - 240V

66717
P.46-47

PLUSH BED **67709**

AIRBED WITH BUILT-IN ELECTRIC PUMP

Item	Size	Approximate Inflated Size	Built-in Pump
67709/E	Queen	60" x 80" x 18"	110 - 120V
67710		(152cm x 203cm x 46cm)	220 - 240V

67709
P.48-49

COMFORT FRAME BED **67971**

AIRBED WITH BUILT-IN ELECTRIC PUMP

Item	Size	Approximate Inflated Size	Hand-held Pump
67971/E	Queen	76" x 95" x 30"	110 - 120V
67972		(193cm x 241cm x 76cm)	220 - 240V

new! 67971
P.56-57

COZY KIDZ™ AIRBED **66801**

COZY KIDZ™ AIRBED

Item	Approximate Inflated Size
66801/E	34½" x 62" x 7" (88cm x 157cm x 18cm)

66801
P.75

ULTRA PLUSH BED **67951**

AIRBED WITH BUILT-IN ELECTRIC PUMP

Item	Size	Approximate Inflated Size	Built-in Pump
67951/E	Twin	39" x 75" x 18"	110 - 120V
67952		(99cm x 191cm x 46cm)	220 - 240V
66957/E	Queen	60" x 80" x 18"	110 - 120V
66958		(152cm x 203cm x 46cm)	220 - 240V

67951
P.52-53

FOAM TOP BED **67953**

AIRBED WITH BUILT-IN ELECTRIC PUMP

Item	Size	Approximate Inflated Size	Built-in Pump
67953/E	Queen	60" x 80" x 20"	110 - 120V
67954		(152cm x 203cm x 51cm)	220 - 240V

new! 67953
P.58-59

KIDZ TRAVEL BED SET **66810**

KIDZ TRAVEL BED SET

Item	Approximate Inflated Size	Hand Pump
66810NP/EP	42" x 66" x 10" (107cm x 168cm x 25cm)	68612

66810
P.76-77

SUPREME AIR-FLOW BED **66963**

AIRBED WITH BUILT-IN ELECTRIC PUMP

Item	Size	Approximate Inflated Size	Built-in Pump
66963/E	Twin	39" x 75" x 20"	110 - 120V
66964		(99cm x 191cm x 51cm)	220 - 240V
66961/E	Queen	60" x 80" x 20"	110 - 120V
66962		(152cm x 203cm x 51cm)	220 - 240V

66963
P.54-55

TAKE ALONG BED **67775**

AIRBED WITH HAND-HELD AC PUMP

Item	Size	Approximate Inflated Size	Hand-held Pump
67775NP/EP	Twin	39" x 75" x 18½"	110 - 120V
67776NP		(99cm x 191cm x 47cm)	220 - 240V

new! 67775
P.78-79

2014 COMFORT COLLECTION

EUROPE
Intex Trading B.V.
Venneveld 9,
4705 RR Roosendaal,
The Netherlands
Tel: (31) 165-593920
Fax: (31) 165-593969
E-mail: info@intexcorp.nl
Web: www.intexcorp.nl

INTERNATIONAL
Intex Development Co., Ltd.
9th Floor, Dah Sing Financial Centre,
108 Gloucester Road, Wanchai,
Hong Kong
Tel: (852) 2827-0000
Fax: (852) 2311-8200
E-mail: info@intexdevelopment.com
Web: www.intexdevelopment.com

Intex Trading s.r.o.
Benešovská 23
101 00 Praha 10
Czech Republic
Tel: (420) 267 312 645
Fax: (420) 267 312 552
E-mail: info@intexcorp.cz
Web: www.intexdevelopment.com

USA
Intex Recreation Corp.
P.O. Box 1440
Long Beach, CA 90801-1440
USA
Tel: (310) 549-5400
Fax: (310) 513-6905
Web: www.intexcorp.com

Unitex Service (France) S.A.S.
Z.A. de Milleure Bois du Ban - N°4
71480 LE MIROIR, France
Tel: (33) 385 75 64 64
Fax: (33) 385 75 64 65
E-mail: info@intexcorp.com.fr
Web: www.intex.fr



©2013 Intex Marketing Ltd. - Intex Development Co., Ltd. - Intex Trading Ltd.
- Intex Recreation Corp. All rights reserved. * Printed in China
®™ Trademarks used in some countries of the world under license from Intex Marketing Ltd.
to Intex Trading Ltd., Intex Development Co., Ltd., G.P.O. Box 28829, Hong Kong, and
Intex Recreation Corp., P.O. Box 1440, Long Beach, CA 90801.

