

# 2017

## Comfort Collection

**INTERNATIONAL**  
 Intex Development Co., Ltd.  
 9th Floor, Dah Sing Financial Centre,  
 108 Gloucester Road, Wanchai,  
 Hong Kong  
 Tel: (852) 2827-0000  
 Fax: (852) 2311-8200  
 E-mail: [info@intexdevelopment.com](mailto:info@intexdevelopment.com)  
 Web: [www.intexdevelopment.com](http://www.intexdevelopment.com)

**USA**  
 Intex Recreation Corp.  
 P.O. Box 1440  
 Long Beach, CA 90801-1440  
 USA  
 Tel: (310) 549-5400  
 Fax: (310) 513-6905  
 Web: [www.intexcorp.com](http://www.intexcorp.com)

**EUROPE**  
 Intex Trading B.V.  
 Venneveld 9,  
 4705 RR Roosendaal,  
 The Netherlands  
 Tel: (31) 165-593920  
 Fax: (31) 165-593969  
 E-mail: [info@intexcorp.nl](mailto:info@intexcorp.nl)  
 Web: [www.intexcorp.nl](http://www.intexcorp.nl)

Intex Trading s.r.o.  
 Benešovská 23  
 101 00 Praha 10  
 Czech Republic  
 Tel: (420) 267 312 645  
 Fax: (420) 267 312 552  
 E-mail: [info@intexcorp.cz](mailto:info@intexcorp.cz)  
 Web: [www.intexdevelopment.com](http://www.intexdevelopment.com)

Unitex Service (France) S.A.S.  
 Z.A. de Milleure Bois du Ban - N°4  
 71480 LE MIROIR, France  
 Tel: (33) 385 75 64 64  
 Fax: (33) 385 75 64 65  
 E-mail: [info@intexcorp.com.fr](mailto:info@intexcorp.com.fr)  
 Web: [www.intex.fr](http://www.intex.fr)

# INTEX®

©2016 Intex Marketing Ltd. - Intex Development Co., Ltd. - Intex Trading Ltd. - Intex Recreation Corp. All rights reserved. • Printed in China  
 ®™ Trademarks used in some countries of the world under license from Intex Marketing Ltd. to Intex Trading Ltd., Intex Development Co., Ltd.,  
 G.P.O Box 28829, Hong Kong, and Intex Recreation Corp., P.O. Box 1440, Long Beach, CA 90801.



COMFORT REST®

2017

# INTEX®

# 2017

## Comfort Collection





Intex Development Co. Ltd., Hong Kong



Intex Recreation Corp, Long Beach, CA, USA



Intex Trading B.V., The Netherlands



Unitex Service (France) S.A.S., France

## INTRODUCTION

The Intex Family of companies is dedicated to developing and manufacturing the highest quality products that not only provide the best value in price, but are innovative, fun and exciting. Backed by excellent Customer Service, Intex also provides first-rate after sales support. The 100+ independently owned and locally operated companies that make up the Intex Family, all embrace this commitment to quality, service and price and are committed to working together to ensure the satisfaction of the families and individuals across the globe who enjoy these products. This has become the hallmark of Intex around the world.

As a true industry leader, Intex boasts state of the art factories, trained and motivated people, products that meet rigorous testing requirements, and a Customer Service organization that will go extra lengths to ensure our customers are satisfied and happy with their purchases.

When you purchase an Intex product you can be confident that you are buying the best product, at the best price, backed by the best Customer Service organization in the industry.

# 2017

Intex is committed to delivering top quality products at a great value with the backing of a responsive Customer Service organization. Our Airbed line is unmatched for breadth and beauty. With the introduction of our new innovative, patented Fiber-Tech™ Technology, we have engineered a way to combine durability with exceptional comfort, creating airbeds that rival the stability, support and comfort of a traditional mattress. The “Dura-Beam®” series utilizes superior Fiber-Tech™ interior construction to create a line of airbeds that are lighter, stronger, and more comfortable than an average airbed. With “PremAire®”, Intex has combined our manufacturing technologies with our engineering strengths of Fiber-Tech™ to bring you the most innovative, luxurious, and comfortable bed in the market today.

Intex Administration Building Landscape, Xiamen, China

Intex Manufacturing and Distribution Complex, Xiamen, China



Our Comfort Rest® line of airbeds consists of four series designed to meet all of your customers' needs: the “Dura-Beam® Basic Series” offers a line of durable and comfortable airbeds with attractive opening price points. “Dura-Beam® Plus Series” features a wide variety of luxurious premium quality raised airbeds. Each airbed has been engineered and tested to provide you with superior functionality that guarantees the ultimate sleeping experience. Our top-of-the-line “PremAire® Airbeds” brings a new level of luxury and innovation to our collection. Elegantly designed with puncture resistant laminated PVC exterior, plushy pillow top and superb structural durability, PremAire® Airbeds brings you and your guest unparalleled comfort. The “Multi-Use / Camping” series is engineered for camping, travel, and all-around rugged use, with beds perfectly suited to the outdoor environment. And for the young at heart, our “Air Furniture” series comes with bright colors and fresh design concepts, guaranteed to attract a loyal following of young adults! Ask your Intex representative for any of our product catalogs – we are confident that you will agree that Intex's product line is unmatched in meeting your needs.



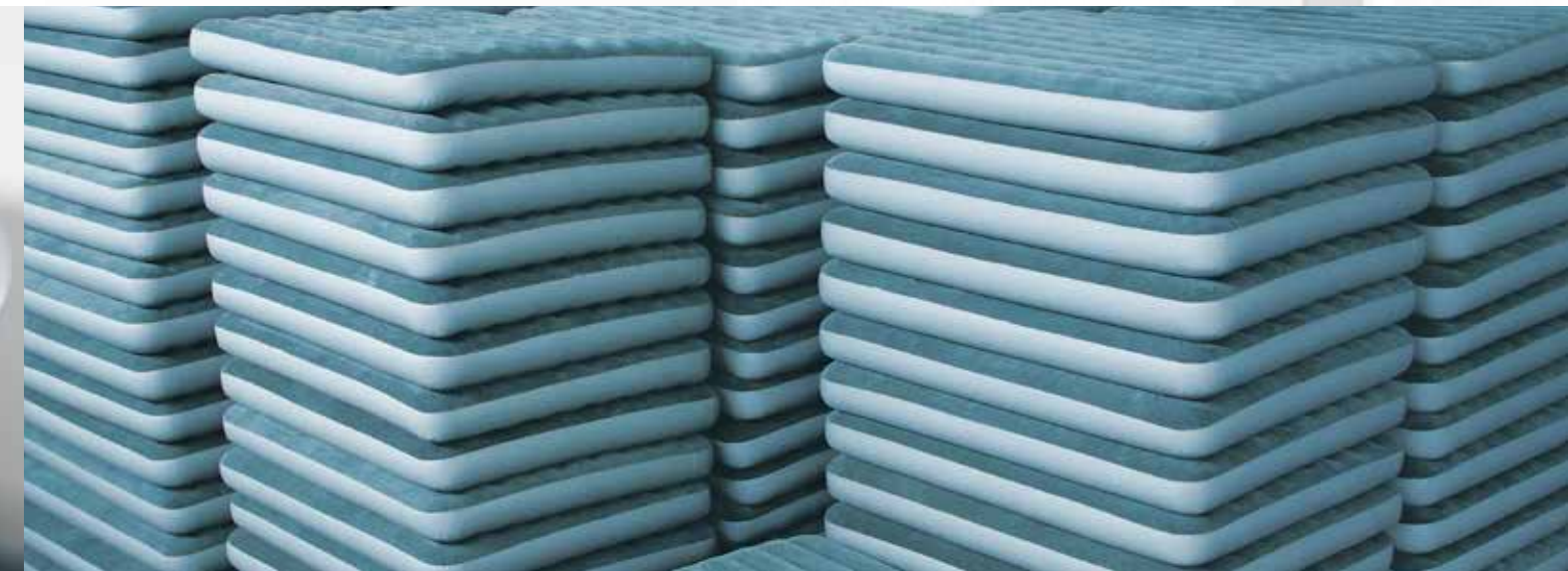

# Commitment to Excellence



100% of our products are quality tested to be air tight before they leave our factory.

Intex's commitment to Excellence encompasses every single product that leaves our factory. We achieve this by maintaining the highest levels of quality assurance – such as inflating and testing every single airbed to ensure the Air Lock® guarantee. It's that simple.



In today's rapidly evolving and highly competitive environment, this translates into a total commitment to product quality, including conformity to all relevant safety & quality regulations and standards. Examples include:

- En 16927, safety and test methods for mini pools (European standard)
- En 16582, safety and test methods for domestic swimming pools other than mini pools (European standard)
- Regulation (EC) No.1907/2006 "Registration, Evaluation, Authorisation and Restriction of Chemicals (REACH)"
- EN 71 "Safety of toys" (European standard)
- EN 13138 "Buoyant aids for swimming instruction" (European standard)
- EN15649 "Floating leisure articles for use on and in the water" (European standard for air mats, lounges and other similar items)
- EN 60335-2-41 "Safety of household and similar electrical appliances, particular requirements for pumps" (European standard for water pumps)
- ISO 6185-1 "Inflatable boats" (International standard for Sports Boats)
- NMMA-ABYC (USA standard for hi-end sports boats)
- ASTM F963 "Standard Consumer Safety Specification for Toy Safety" (USA toy standard)
- ANSI/APSP-4 "AGP standard" (USA standard for above ground pools)
- CPSIA "Consumer Product Safety Improvement Act" (USA regulation of consumer and children's products)
- ASTM F2666 "Small pools standard" (USA standard for pools under 36" water depth)

- UL1450 "Electric inflators" (USA standard for electric inflators)
- UL1081 "Swimming pool pumps, filters and chlorinators" (USA standard)
- UL1563 "Electric Spas" (USA standard for Spa)

Intex's commitment to Excellence extends to helping our environment and supporting the ecosystem. It begins with product design. Intex's filter pumps operate on much lower amps than most filter pumps in the market, reducing electricity consumption. Our saltwater systems clean pools using only natural salt, eliminating the ongoing need for environmentally unfriendly packaged chlorine.

Intex also operates one of the most comprehensive recycling programs in the industry. We are one of the earliest companies in China to successfully obtain a license to ship consumers' returns in the original package back to China to be recycled. Therefore, used materials and product returns are prevented from going to landfills and instead re-used in the manufacturing process where up to 10% of annually produced PVC is recycled.

Intex designs all of our own packaging for our products. We constantly challenge our methods of packaging to improve efficiency and reduce waste. More compact packaging

techniques save cardboard while cutting down on space utilization, saving freight and fuel consumption.

As a manufacturer, Intex knows it has a responsibility to manage the amount of waste produced. As an employer of over ten thousand people, we also encourage our own employees to recycle, reduce waste, and be conscious of the environment. Starting from recycling corners for all our worldwide office facilities, our Factory has worked with the local government as well as through sponsorships with key partners to strengthen our efforts to be more eco-friendly. Intex has worked to provide incentives and seminars to employees as well as setting targets to reduce energy consumption. In addition, Intex has made significant investment in technology to achieve these goals. For example, we have implemented a frequency converter system which converts diesel to natural gas, installed solar water heaters and set up a recycled sewage system, and invested in equipment that reduces gas emissions.

From product design, to more efficient processes that save energy and reduce waste, to a world class recycling program, to more energy efficient offices, the people at Intex are striving to provide the best value products anywhere while constantly keeping our global ecosystem in mind.



08	Fiber-Tech™ Technology
12	Dura-Beam® Basic Series
20	Dura-Beam® Plus Series
32	PremAire® Airbeds
38	Multi-Use / Camping
50	Air Furniture
68	Accessories



100% of our products are  
quality tested to be air tight  
before they leave our factory.



# 2017



INTRODUCING

# FIBER-TECH™ TECHNOLOGY

by INTEX®

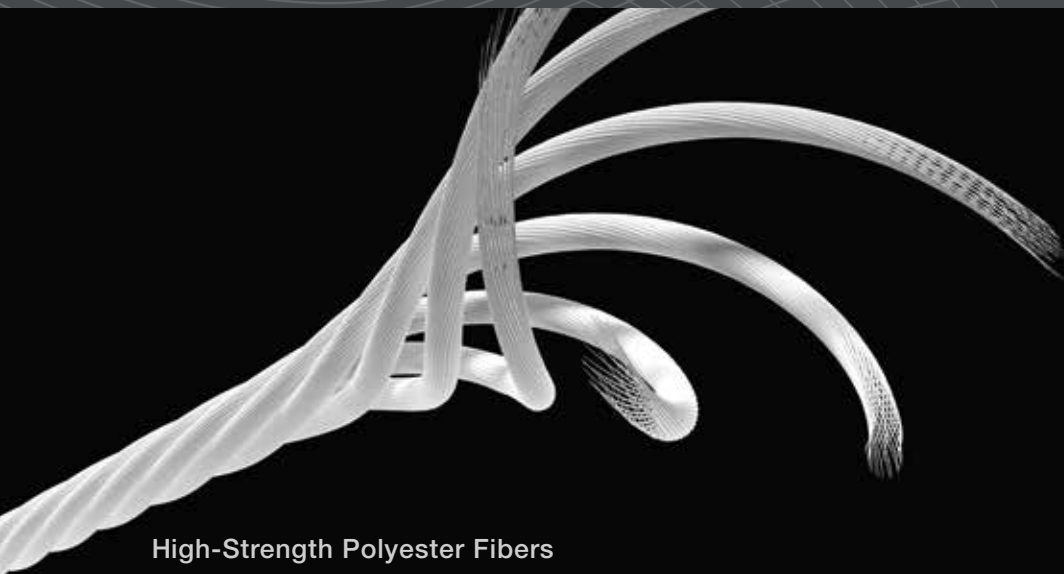

High-Strength Polyester Fibers



Fiber-Tech™ Interior Construction



## CONTOURED SUPPORT SYSTEM

Our new innovative, patented Fiber-Tech™ Technology airbeds are comprised of thousands of high-strength polyester fibers. Unlike traditional airbed construction, these high-strength polyester fibers do not stretch over time, resulting in amazing durability for years of lasting comfort. Fiber-Tech™ interior construction provides the ideal firmness for superb support and rejuvenating sleep.



An Incredible Night's Sleep Starts With a Single Thread...

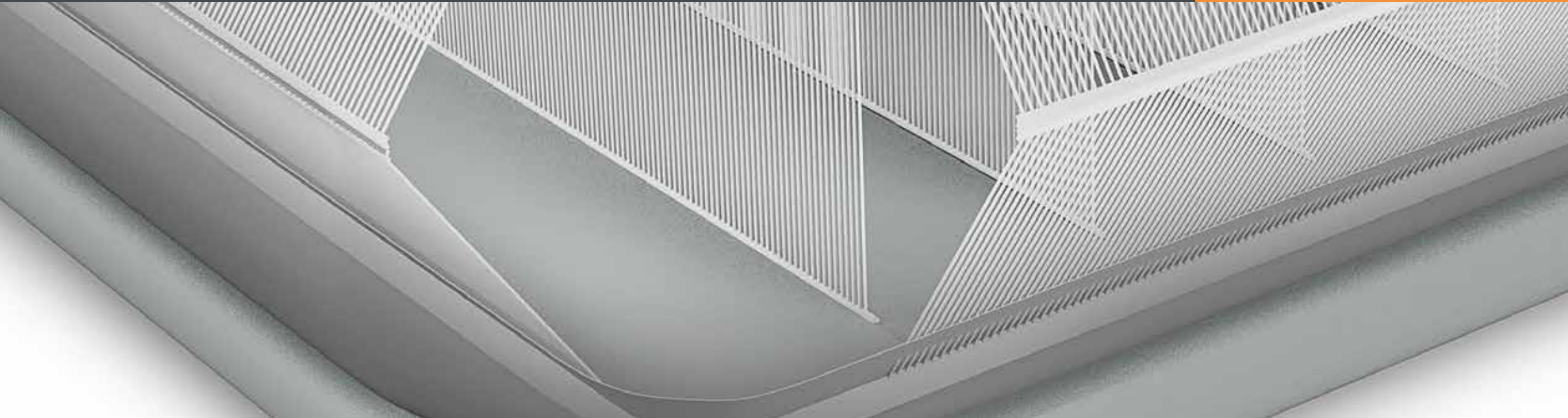



# Designed for Comfort Engineered for Durability

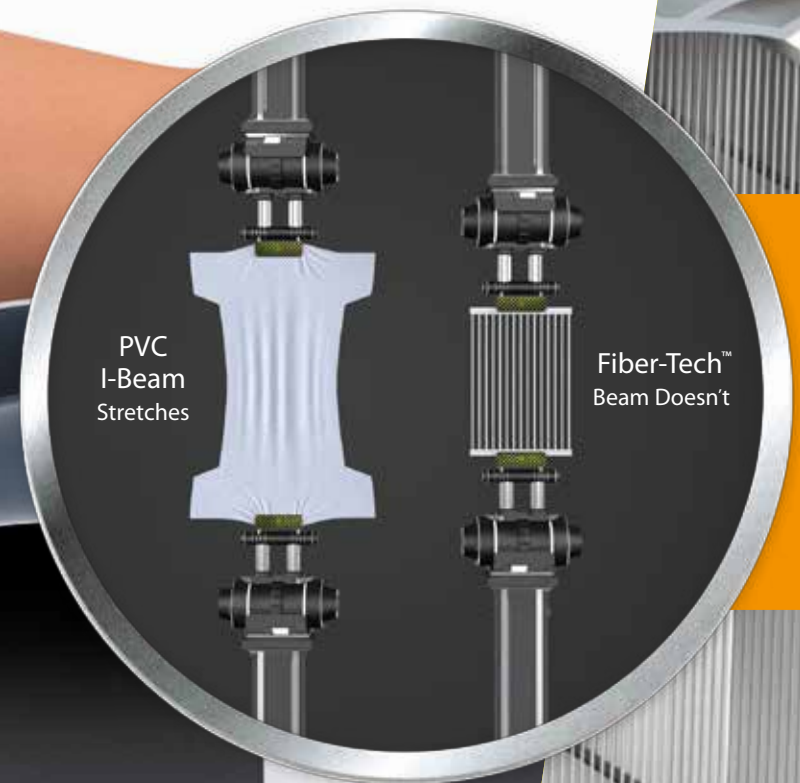

**FIBER-TECH™**  
**TECHNOLOGY**

Standard interior construction has been enhanced with lightweight, high-strength fibers for amazing durability and comfort!

U.S. Patent No. 8,562,773 and U.S. Patent No. 9,156,203



DURA-BEAM® BASIC SERIES

DELUXE  
SINGLE-HIGH  
WITH FIBER-TECH™ TECHNOLOGY



INDOOR / OUTDOOR MULTI-USE  
SINGLE-HIGH AIRBED

- Fiber-Tech™ Technology
- Quality tested flocced top and sides with vinyl bottom
- Strong and lightweight
- 2-in-1 valve



SHELF BOX FOLDS COMPACTLY

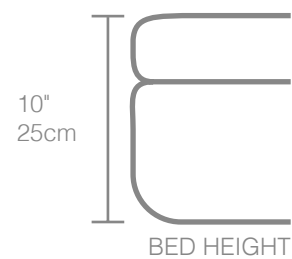
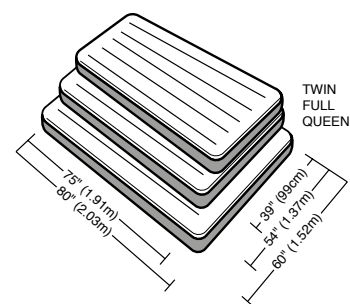

NEW

AIRBED

only

		Approximate Inflated Size	Case Pack	Case Weight
64707 / E	Twin	39" x 75" x 10" 99cm x 1.91m x 25cm	4 ea	24.5 lb (11.2 kg)
64708 / E	Full	54" x 75" x 10" 1.37m x 1.91m x 25cm	3 ea	24.4 lb (11.1 kg)
64709 / E	Queen	60" x 80" x 10" 1.52m x 2.03m x 25cm	3 ea	28.1 lb (12.8 kg)

Introducing 10" (25cm) Deluxe Single-High Airbed with Fiber-Tech™ Technology. The perfect all-around sleeping solution, this compact airbed provides both campers and in-home users with the convenience of a low-profile, light-weight, comfortable bed that is built for long-lasting durability.

This airbed is covered in a soft, flocced sleeping surface for enhanced comfort. Our patented Fiber-Tech™ interior construction provides superb support and structural stability for a restful night's sleep. Made for durability and comfort, anywhere you go.

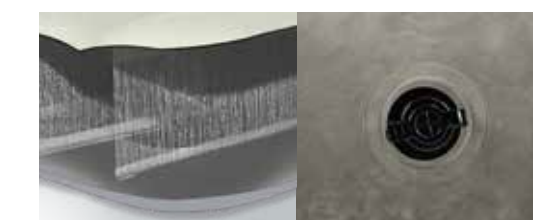

Fiber-Tech™ Technology

2-in-1 valve with extra-wide openings for fast inflating and deflating



DURA-BEAM® BASIC SERIES

PILLOW REST  
RAISED BED

WITH FIBER-TECH™ TECHNOLOGY



Built-in pillow for added convenience



ELEVATED FOR CONVENIENCE

- Fiber-Tech™ Technology
- Mattress is raised 16½" (42cm) from the floor for convenience
- A built-in pillow provides bed-like comfort



AC Electric Pump INFLATING TIMES*	
TWIN	2 Minutes
QUEEN	3 Minutes

\*INFLATING TIME VARIES BY MATTRESS SIZE AND DESIRED FIRMNESS

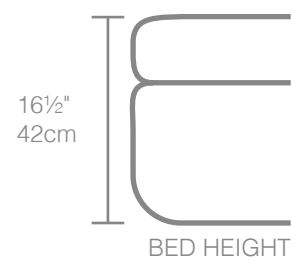
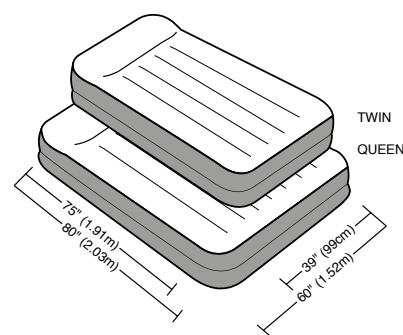

NEW

AIRBED

with Built-in Electric Pump

		Approximate Inflated Size	Built-in Pump	Case Pack	Case Weight
64121E	Twin	39" x 75" x 16½"	110 - 120V	3 ea	32.1 lb (14.6 kg)
64122		99cm x 1.91m x 42cm	220 - 240V		
64123E	Queen	60" x 80" x 16½"	110 - 120V	2 ea	31.5 lb (14.3 kg)
64124		1.52m x 2.03m x 42cm	220 - 240V		

Our best-selling Pillow Rest Raised Bed has been enhanced with Fiber-Tech™ interior construction, providing you added comfort and durability, and an overall better sleeping experience.



Fiber-Tech™ Technology

Built-in AC Electric Pump



DURA-BEAM® BASIC SERIES

DELUXE PILLOW REST RAISED BED

WITH FIBER-TECH™ TECHNOLOGY



Built-in pillow for added convenience



BUILT-IN PILLOW AND SOFT FLOCKED TOP FOR COMFORT

- Fiber-Tech™ Technology
- Mattress is raised 16½" (42cm) from the floor for convenience
- Indented sides positioned perfectly to keep fitted sheets firmly in place



AC

Electric Pump

INFLATING TIMES\*

TWIN	2 Minutes
QUEEN	3 Minutes

\*INFLATING TIME VARIES BY MATTRESS SIZE AND DESIRED FIRMNESS

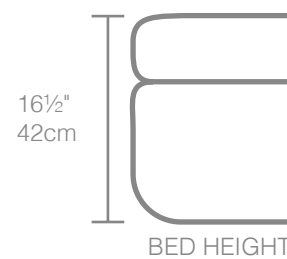
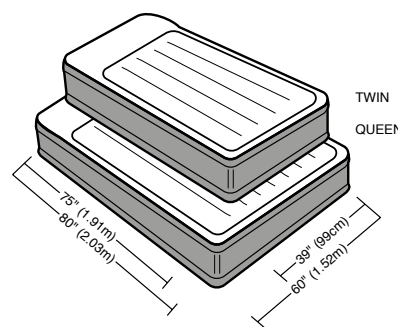

NEW

AIRBED

with Built-in Electric Pump

		Approximate Inflated Size	Built-in Pump	Case Pack	Case Weight
64131E	Twin	39" x 75" x 16½"	110 - 120V	3 ea	36.1 lb (16.4 kg)
64132		99cm x 1.91m x 42cm	220 - 240V		
64135E	Queen	60" x 80" x 16½"	110 - 120V	2 ea	34.5 lb (15.7 kg)
64136		1.52m x 2.03m x 42cm	220 - 240V		

A deluxe version of our Pillow Rest Raised Bed! Modified with Fiber-Tech™ interior construction, overnight guests will enjoy the added comfort, support and firmness this mattress brings. The outer perimeter frame on the sleeping surface provides added edge support – making the bed feel roomier and easier to get in and out of.



Deluxe Pillow Rest Construction

Built-in AC Electric Pump



DURA-BEAM® BASIC SERIES

ESSENTIAL REST AIRBED

WITH FIBER-TECH™ TECHNOLOGY



ELEVATED FOR COMFORT & CONVENIENCE

- Fiber-Tech™ Technology
- The Dual-chamber construction provides ample vertical stability
- Mattress is raised 20" (51cm) from the floor for convenience
- Cozy flocked mattress top



<b>AC</b> Electric Pump INFLATING TIMES*	
QUEEN	3½ minutes

\*INFLATING TIME VARIES BY MATTRESS SIZE AND DESIRED FIRMNESS

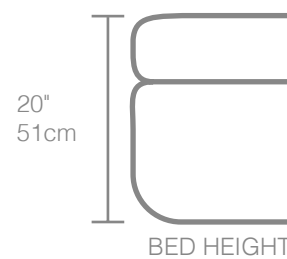
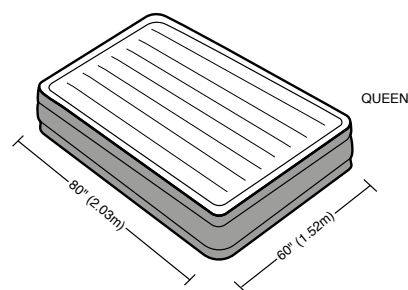

NEW

**AIRBED**

with Built-in Electric Pump

		Approximate Inflated Size	Built-in Pump	Case Pack	Case Weight
64139E	Queen	60" x 80" x 20"	110 - 120V	2 ea	36.5 lb (16.6 kg)
64140		1.52m x 2.03m x 51cm	220 - 240V		

Our Essential Rest Airbed with Fiber-Tech™ interior construction features a traditional bed height so guests will feel right at home. Your house guests will love the better support and firmness Fiber-Tech™ Technology brings. The indented sides help grip fitted sheets. The outer perimeter frame on both top and bottom provides additional stability and support. This full-featured bed is all you need for a great night's sleep.



Fiber-Tech™ Technology

Built-in AC Electric Pump



DURA-BEAM® PLUS SERIES

COMFORT-PLUSH

WITH FIBER-TECH™ TECHNOLOGY

Our most popular bed in the Dura-Beam® series with three different bed heights to choose from, our Comfort-Plush beds offer the perfect combination of luxurious comfort and convenience.



Each bed is covered in plush flocking that is soft to the touch, and the horizontal air chambers provide added stability and support around the entire bed. For extra convenience, this bed comes with a powerful built-in electric pump for fast inflation and deflation.

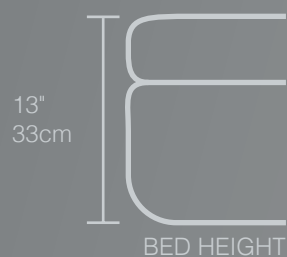

AC Electric Pump INFLATING TIMES*	
TWIN	2 Minutes
FULL	3 Minutes
QUEEN	3 Minutes

\*INFLATING TIME VARIES BY MATTRESS SIZE AND DESIRED FIRMNESS



COMFORT-PLUSH HORIZONTAL BEAM AIRBED

- Fiber-Tech™ Technology
- Quality tested flocked top and sides with vinyl bottom

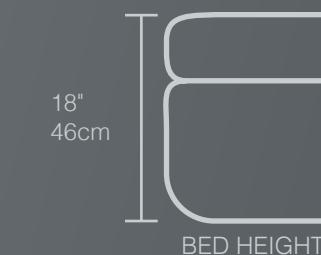

AC Electric Pump INFLATING TIMES*	
TWIN	2½ Minutes
QUEEN	4 Minutes

\*INFLATING TIME VARIES BY MATTRESS SIZE AND DESIRED FIRMNESS

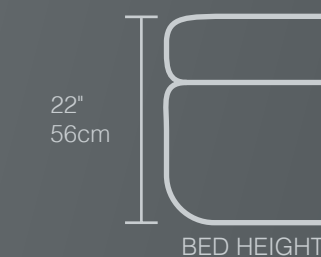

AC Electric Pump INFLATING TIMES*	
QUEEN	4½ Minutes

\*INFLATING TIME VARIES BY MATTRESS SIZE AND DESIRED FIRMNESS

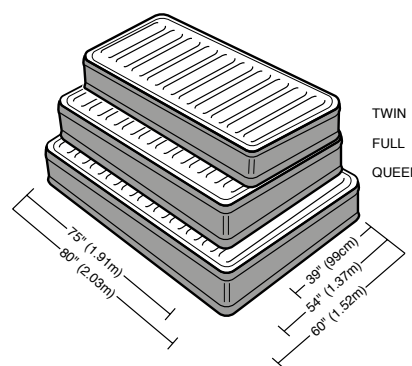

AIRBED with Built-in Electric Pump		Approximate Inflated Size	Built-in Pump	Case Pack	Case Weight
67765E	Twin	39" x 75" x 13"	110 - 120V	3 ea	39.8 lb (18.1 kg)
67766		99cm x 1.91m x 33cm	220 - 240V		
67767E	Full	54" x 75" x 13"	110 - 120V	2 ea	32.4 lb (14.7 kg)
67768		1.37m x 1.91m x 33cm	220 - 240V		
67769E	Queen	60" x 80" x 13"	110 - 120V	2 ea	36.7 lb (16.7 kg)
67770		1.52m x 2.03m x 33cm	220 - 240V		

AIRBED with Built-in Electric Pump		Approximate Inflated Size	Built-in Pump	Case Pack	Case Weight
64411E	Twin	39" x 75" x 18"	110 - 120V	3 ea	44.0 lb (20.0 kg)
64412		99cm x 1.91m x 46cm	220 - 240V		
64413E	Queen	60" x 80" x 18"	110 - 120V	2 ea	40.9 lb (18.6 kg)
64414		1.52m x 2.03m x 46cm	220 - 240V		
64417E	Queen	60" x 80" x 22"	110 - 120V	2 ea	46.7 lb (21.2 kg)
64418		1.52m x 2.03m x 56cm	220 - 240V		



Fiber-Tech™ Technology

Built-in AC electric pump



DURA-BEAM® PLUS SERIES

ULTRA PLUSH BED  
WITH FIBER-TECH™ TECHNOLOGY



ELEVATED WITH BUILT-IN ELECTRIC PUMP

- Fiber-Tech™ Technology
- Textured pillowtop for added comfort
- 18" (46cm) Raised height
- Built-in pump for rapid inflation and deflation



AC Electric Pump INFLATING TIMES*	
TWIN	2 Minutes
QUEEN	3½ Minutes

\*INFLATING TIME VARIES BY DESIRED FIRMNESS

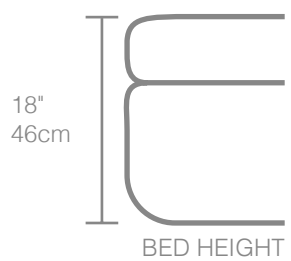
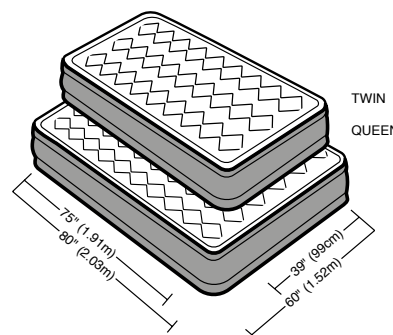

**AIRBED**

with Built-in Electric Pump		Approximate Inflated Size	Built-in Pump	Case Pack	Case Weight
64455E	Twin	39" x 75" x 18"	110 - 120V	2 ea	29.3 lb (13.3 kg)
64456		99cm x 1.91m x 46cm	220 - 240V		
64457E	Queen	60" x 80" x 18"	110 - 120V	2 ea	40.3 lb (18.3 kg)
64458		1.52m x 2.03m x 46cm	220 - 240V		

Here's an airbed that is sure to impress your most important guests: The Ultra Plush Bed is newly redesigned with revolutionary Fiber-Tech™ Technology. This raised bed combines comfort, convenience, and great appearance into one luxurious airbed, with its unique textured sleeping surface and inflated outer perimeter band for superior stability, comfort and support.



Fiber-Tech™ Technology

Built-in AC Electric Pump



DURA-BEAM® PLUS SERIES

PRIME COMFORT  
ELEVATED AIRBED

WITH FIBER-TECH™ TECHNOLOGY



Intex's Luxurious Double Patterned Flocking



ELEVATED WITH BUILT-IN  
ELECTRIC PUMP

- Fiber-Tech™ Technology
- 20" (51cm) Raised height
- Double Layered construction



AC Electric Pump INFLATING TIMES*	
TWIN	2 Minutes
QUEEN	3½ Minutes

\* INFLATING TIME VARIES BY MATTRESS SIZE AND DESIRED FIRMNESS

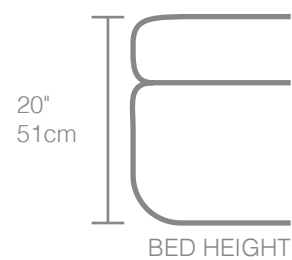
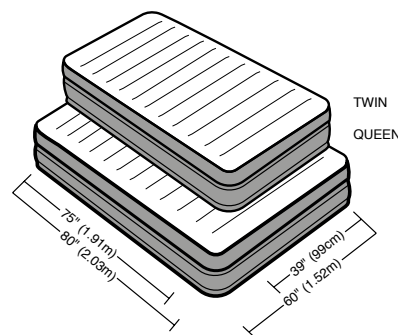

NEW

AIRBED

with Built-in Electric Pump

		Approximate Inflated Size	Built-in Pump	Case Pack	Case Weight
64443E	Twin	39" x 75" x 20"	110 - 120V	2 ea	35.2 lb (16.0 kg)
64444		99cm x 1.91m x 51cm	220 - 240V		
64445E	Queen	60" x 80" x 20"	110 - 120V	1 ea	24.9 lb (11.3 kg)
64446		1.52m x 2.03m x 51cm	220 - 240V		

Introducing the new 20" Prime Comfort Elevated Airbed with Fiber-Tech™ Technology, the perfect all around sleeping solution with an enhanced soft, fleece flocked top. The double layered construction allows you to tuck in standard size queen bed sheets easily and securely. Our patented Fiber-Tech™ interior construction provides superb support and structural stability for restful night sleep. For added convenience the powerful built-in pump easily inflates and deflates the airbed within minutes.



Double-Layer Construction

Built-in AC Electric Pump



DURA-BEAM® PLUS SERIES

SUPREME AIR-FLOW BED

WITH FIBER-TECH™ TECHNOLOGY



ELEVATED WITH BUILT-IN ELECTRIC PUMP

- Fiber-Tech™ Technology
- 20" (51cm) Raised height
- Plush Velvetaire™ pillow top mattress surface
- Inflated bed fits standard sheets
- Network of inter-connected air pockets that allow air to flow smoothly and gradually across the top and side surfaces



AC Electric Pump INFLATING TIMES*	
TWIN	2½ Minutes
QUEEN	4 Minutes

\*INFLATING TIME VARIES BY MATTRESS SIZE AND DESIRED FIRMNESS

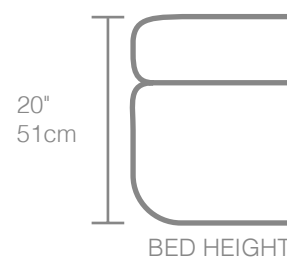
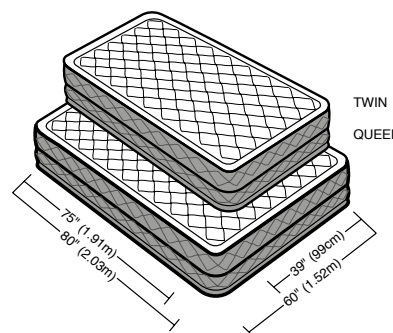

AIRBED

with Built-in Electric Pump

		Approximate Inflated Size	Built-in Pump	Case Pack	Case Weight
64461E	Twin	39" x 75" x 20"	110 - 120V	1 ea	26.0 lb (11.8 kg)
64462		99cm x 1.91m x 51cm	220 - 240V		
64463E	Queen	60" x 80" x 20"	110 - 120V	1 ea	36.2 lb (16.5 kg)
64464		1.52m x 2.03m x 51cm	220 - 240V		

Our Supreme Air-Flow Bed is engineered to provide the ultimate in comfort with the look and feel of a real high end bed. A network for inter-connected air pockets on the top and sides of the bed cause the air to flow smoothly and gradually across the sleeping surface for unbelievable comfort and stability. Constructed with innovative Fiber-Tech™ Technology, this mattress is firmer and more durable than ever before. The dual chamber construction provides firm support and allows for fitted sheets to tuck in easily. Topped with super soft Veletaire™ flocking this bed rivals any traditional mattress in comfort and stability.



Double-Layer Beam Construction  
U.S. Patent No. 7,636,970

Built-in AC Electric Pump



DURA-BEAM® PLUS SERIES

FOAM  
TOP BED

WITH FIBER-TECH™ TECHNOLOGY



ELEVATED WITH BUILT-IN  
ELECTRIC PUMP

- Fiber-Tech™ Technology
- Foam Top Layer
- 20" (51cm) Raised height
- Plush Velvetaire™ Flocked mattress surface



CARRY BAG    SHELF BOX    BUILT IN AIR PUMP

**AC**  
Electric Pump  
INFLATING TIMES\*

QUEEN	3½ minutes
-------	---------------

\*INFLATING TIME VARIES BY DESIRED FIRMNESS

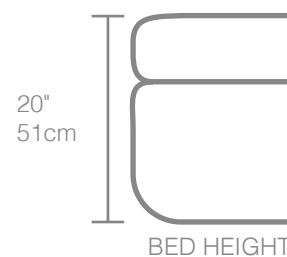
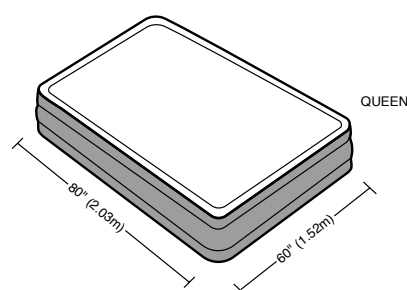

**AIRBED**

with Built-in Electric Pump

		Approximate Inflated Size	Built-in Pump	Case Pack	Case Weight
64467E	Queen	60" x 80" x 20"	110 - 120V	1 ea	24.8 lb (11.3 kg)
64468		1.52m x 2.03m x 51cm	220 - 240V		

Guests will enjoy a luxurious night's sleep with the cozy Foam Top High-Rise Airbed. The soft Plush Velvetaire™ flocking surface and foam top layer comfortably contours the body for a rejuvenating sleeping experience. Made with the innovative Fiber-Tech™ Technology, this mattress is firmer and more durable than ever before. Raised edges provide stability and added support while the indented sides ensure your standard queen fitted sheets tuck in easily and securely.



Fiber-Tech™ Technology

Built-in  
AC Electric Pump



DURA-BEAM® PLUS SERIES

ULTRA PLUSH  
HEADBOARD BED

WITH FIBER-TECH™ TECHNOLOGY



ELEVATED WITH BUILT-IN  
ELECTRIC PUMP

- Fiber-Tech™ interior construction
- Headboard keeps your pillows from falling off the bed throughout the night, and provides support when sitting up
- 18" (46cm) height provides easier access onto and off of the bed
- Vinyl puncture resistant sides add durability
- Pillow top surface delivers exceptional comfort



<b>AC</b> Electric Pump INFLATING TIMES*	
QUEEN	4½ minutes

\*INFLATING TIME VARIES BY DESIRED FIRMNESS

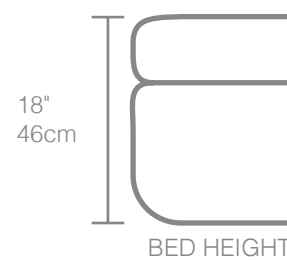
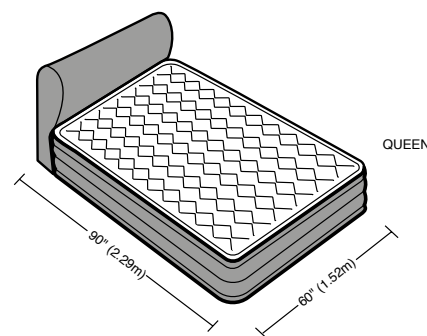

**AIRBED**

with Built-in Electric Pump

		Approximate Inflated Size	Built-in Pump	Case Pack	Case Weight
64459E	Queen	60" x 90" x 31"	110 - 120V	1 ea	24.9 lb (11.3 kg)
64460		1.52m x 2.29m x 79cm	220 - 240V		

Get a quality night's sleep with the new Dura-Beam® Series Headboard Bed. The built-in headboard is versatile. It can be used as an ideal back support when lounging or watching T.V. and as a pillow stopper when sleeping, keeping your pillows from falling on the floor. The pillow top surface gives a cushioned feel for maximum comfort.



Fiber-Tech™ Technology

Built-in  
AC Electric Pump



# REDEFINING THE AIRBED

## INTRODUCING

# PremAire®

Elevated Series  
with Fiber-Tech™ Technology

Intex is proud to bring you a new level of luxury and innovation with the latest edition to our unrivaled airbed line, the PremAire® Elevated Series with Fiber-Tech™ Technology.

Built with our patented Fiber-Tech™ Technology, our PremAire® beds offer superb structural stability and support. The high-strength fibers provide an interior with amazing durability and unmatched comfort. The exterior of the mattress is made of laminated PVC to provide a high quality puncture resistant surface. Each mattress is covered in a pillow top that creates air pockets that cause air to flow smoothly and gradually across the surface for an unparalleled sleeping experience.

The bed's elevated height makes it easier to get in and out of each morning. For extra convenience, this bed comes with a powerful built-in electric pump for fast inflation and deflation. Our new revolutionary PremAire® mattress offers the perfect combination of luxurious comfort and best-in-class durability.

# INTEX®

INTEX®

# PremAire®

WITH FIBERTECH™ TECHNOLOGY



# THE MOST ADVANCED AIRBED TECHNOLOGY

Luxurious flocked pillow top with heavy duty 2-ply laminated side walls and bottom

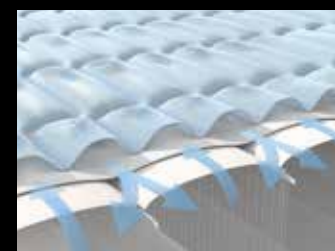

### LUXURIOUS PILLOW TOP

Hundreds of inter-connected air pockets engineered so that air flows gently across the sleeping surface creating body-hugging comfort



### SLEEK BUILT-IN PUMP

Newly designed pump panel with firmness control dial, LED night light and USB port



### BUILT-IN STORAGE WITH 2-IN-1 VALVE

Convenient storage for cord and small personal items. 2-in-1 Valve included for easy inflation and deflation with manual pump. Ideal for outdoor use.

### LIGHTWEIGHT CARRY BAG

Stylish carry bag for easy storage and transport

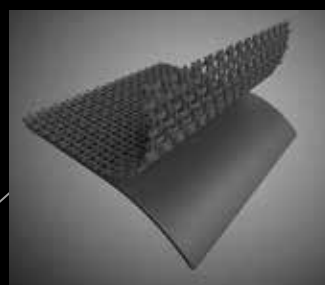

### HEAVY DUTY 2-PLY MATERIAL

The 2-ply laminated side walls and bottom firmly retain air while providing a high quality puncture-resistant surface

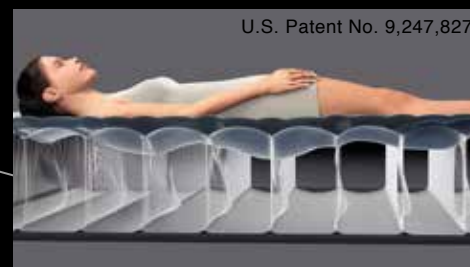

### REVOLUTIONARY FIBER-TECH™ TECHNOLOGY

Revolutionary, patented Fiber-Tech™ support system provides the perfect combination of superb structural stability and support



### 100% QUALITY TESTED

100% of our airbeds are quality tested to be air tight before they leave our factory



### QUALITY ASSURED

Peace of mind 1 year warranty

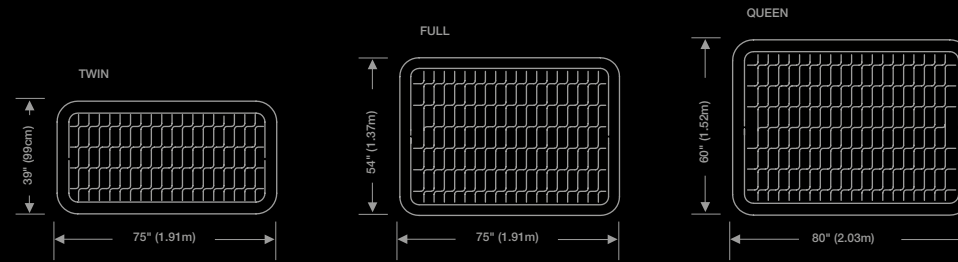

Item	Size	Approximate Inflated Size	Built-in Pump	Case Pack	Case Weight
NEW 64481E	Twin	39" x 75" x 18"	110-120V	2 ea	36.6 lb (16.6 kg)
64482		99cm x 1.91m x 46cm	220-240V		
NEW 64483E	Full	54" x 75" x 18"	110-120V	1 ea	22.6 lb (10.3 kg)
64484		1.37m x 1.91m x 46cm	220-240V		
NEW 64485E	Queen	60" x 80" x 18"	110-120V	1 ea	25.3 lb (11.5 kg)
64486		1.52m x 2.03m x 46cm	220-240V		

18in  
Bed Height

INFLATING TIMES*	
AC Electric Pump	
Twin	2½ minutes
Full	4 minutes
Queen	4½ minutes

\* Inflating time varies by mattress size and desired firmness



## THE MOST INNOVATIVE AIRBED TECHNOLOGY

Six sided heavy duty 2-ply all laminated Dream Support Airbed  
U.S. Patent No. 8,562,773 and No. 9,156,203



### REVOLUTIONARY FIBER-TECH™ TECHNOLOGY

Revolutionary, patented Fiber-Tech™ support system provides the perfect combination of superb structural stability and support



### SLEEK BUILT-IN PUMP

Newly designed pump panel with firmness control dial, LED night light and USB port



### BUILT-IN STORAGE WITH 2-IN-1 VALVE

Convenient storage for cord and small personal items. 2-in-1 Valve included for easy inflation and deflation with manual pump. Ideal for outdoor use.

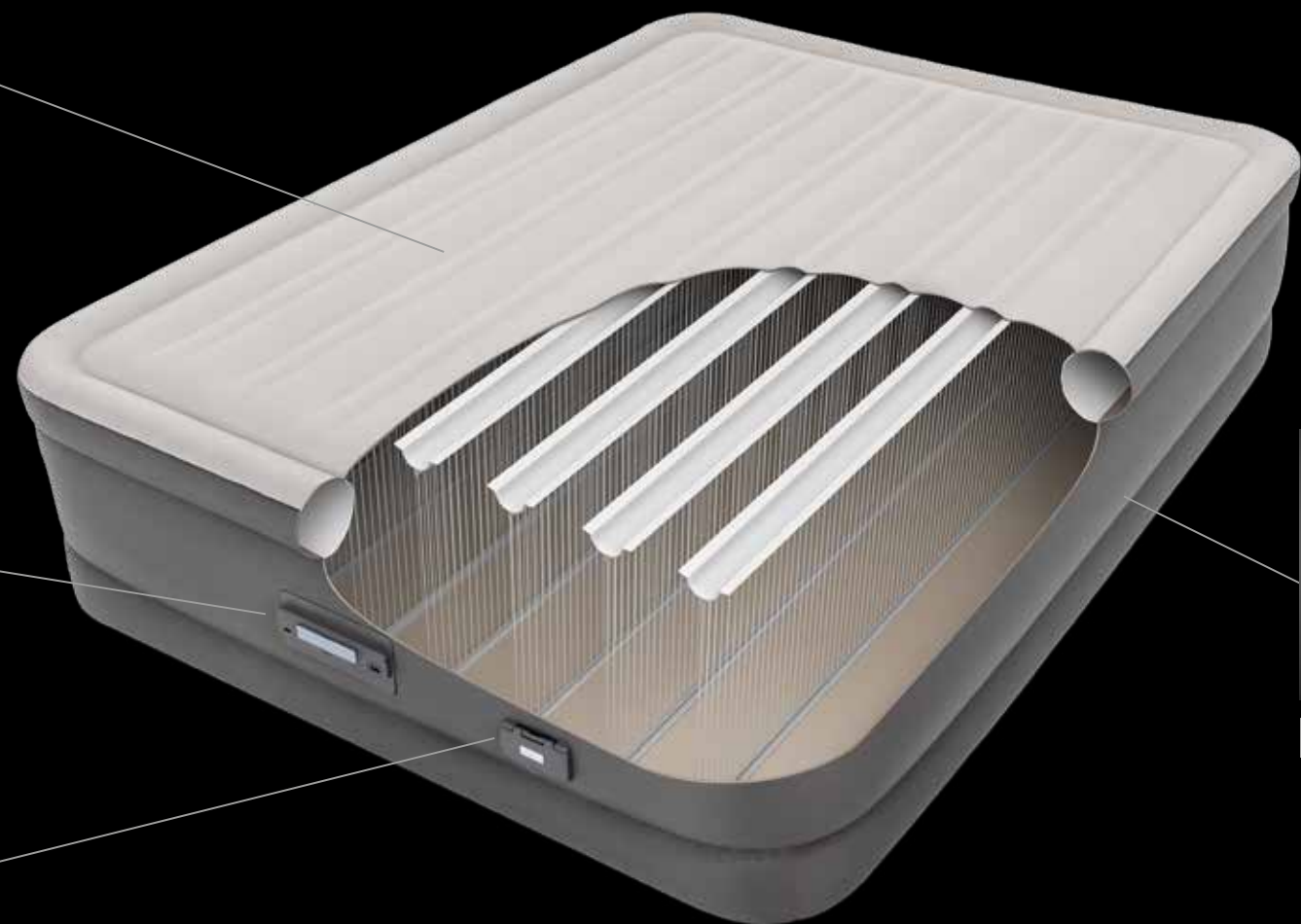

### LIGHTWEIGHT CARRY BAG

Stylish carry bag for easy storage and transport

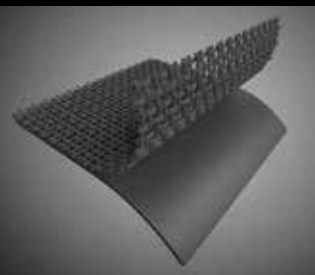

### HEAVY DUTY 2-PLY MATERIAL

The 2-ply fully laminated airbed firmly retains air while providing a perfect combination of superior durability, firmness, and comfort

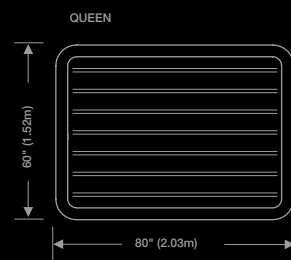

Item	Size	Approximate Inflated Size	Built-in Pump	Case Pack	Case Weight
64769E	Queen	60" x 80" x 18"	110-120V	1 ea	20.3 lb (9.2 kg)
64770		1.52m x 2.03m x 46cm	220-240V		

18in  
Bed  
Height

### INFLATING TIMES\*

AC Electric Pump

Queen 4½ minutes

\* Inflating time varies by mattress size and desired firmness



100% QUALITY TESTED

100% of our airbeds are quality tested to be air tight before they leave our factory

1 YEAR LIMITED WARRANTY

QUALITY ASSURED

Peace of mind  
1 year warranty



# MULTI-USE

Intex knows that disconnecting from the pace of modern life doesn't mean giving up comfort. Intex Camping Airbeds have all been specifically designed to provide an uncompromising level of style, durability, comfort, and ease. Intex Camping Airbeds come in a variety of shapes, sizes, and styles to suit nearly any outdoor adventure.

Enjoy the Great Outdoors

## DOWNY BED

This airbed has a flocked top that provides a more comfortable sleeping surface. Its unique wave beam construction eliminates uncomfortable surface bumps and provides a flat, uniform sleeping surface. The Downy airbed can be inflated with either the built-in manual foot pump or a regular pump.

### BUILT-IN FOOT PUMP FOR CONVENIENCE

- Unique built-in bellow foot pump for convenience-no separate pump needed. Just step down to inflate and the pump springs back automatically for the next cycle
- New and improved foot pump construction allows for faster inflation
- 2-in-1 valve for inflating with optional electric or manual pumps
- Conventional mattress sizes (L x W) for more sleeping area and a better fit for sheets
- 8¾" (22cm) mattress thickness for extra soft comfort

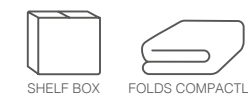

SHELF BOX FOLDS COMPACTLY

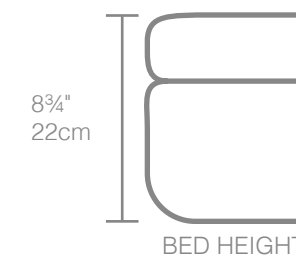

BED HEIGHT

INFLATING TIMES*	
COT SIZE	2 Minutes
TWIN	3 Minutes
FULL	3 Minutes
QUEEN	4 Minutes

\*INFLATING TIME VARIES BY MATTRESS SIZE AND DESIRED FIRMNESS

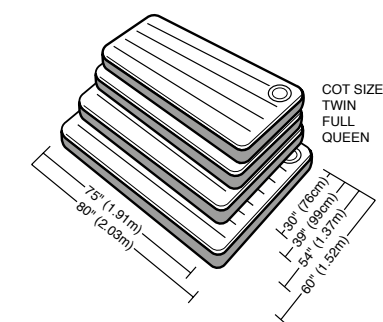

COT SIZE  
TWIN  
FULL  
QUEEN

### AIRBED

with Built-in Foot Pump

		Approximate Inflated Size	Case Pack	Case Weight
66950 / E	Cot Size	30" x 75" x 8¾" 76cm x 1.91m x 22cm	6 ea	36.4 lb (16.6 kg)
66927 / E	Twin	39" x 75" x 8¾" 99cm x 1.91m x 22cm	4 ea	29.8 lb (13.5 kg)
66928 / E	Full	54" x 75" x 8¾" 1.37m x 1.91m x 22cm	3 ea	28.3 lb (12.9 kg)
66929 / E	Queen	60" x 80" x 8¾" 1.52m x 2.03m x 22cm	3 ea	32.3 lb (14.7 kg)



Wave Beam Construction

Built-in lightweight foot pump for easy inflation - No separate pump or power supply needed!



# PRESTIGE DOWNY BED



Wave Beam Construction

For home or camping  
Operates on 6 C-cell batteries (not included)

The perfect camping companion

The perfect choice for the rugged outdoors. The flocked top provides a comfortable sleeping surface, and is easy to clean. The powerful battery-operated (6 x C-cell) pump goes anywhere!

### WITH HAND-HELD BATTERY PUMP

- 3-in-1 valve has extra-wide openings for fast inflating and deflating
- Conventional mattress sizes (L x W) for more sleeping area and a better fit for sheets
- Battery pump can also be used on other inflatables
- 8¾" (22cm) mattress thickness for extra soft comfort



SHELF BOX



FOLDS COMPACTLY

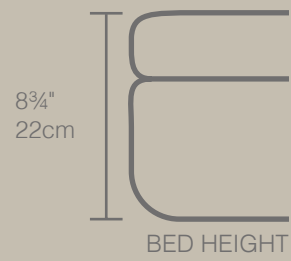

INFLATING TIMES*	
TWIN	2 Minutes
FULL	2 Minutes
QUEEN	2 1/2 Minutes

\*INFLATING TIME VARIES BY MATTRESS SIZE AND DESIRED FIRMNESS

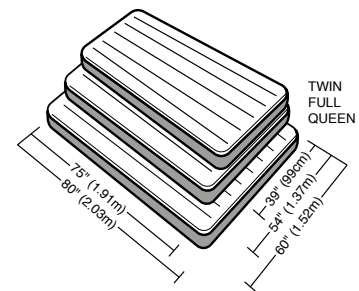

## AIRBED

with Handheld 6 C-Cell Battery Pump

		Approximate Inflated Size	Case Pack	Case Weight
66967 / E	Twin	39" x 75" x 8¾" 99cm x 1.91m x 22cm	4 ea	30.4 lb (13.8 kg)
66968 / E	Full	54" x 75" x 8¾" 1.37m x 1.91m x 22cm	3 ea	29.0 lb (13.2 kg)
66969 / E	Queen	60" x 80" x 8¾" 1.52m x 2.03m x 22cm	3 ea	33.4 lb (15.2 kg)



# CLASSIC DOWNY BED



Wave Beam Construction

Airbed Set (#68765/E)

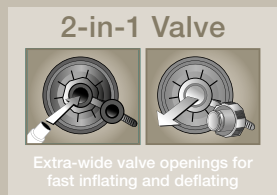

Extra-wide valve openings for fast inflating and deflating

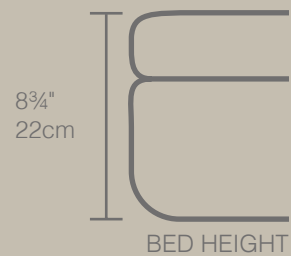

INFLATING TIMES*	
QUEEN	5 Minutes

\*INFLATING TIME VARIES BY MATTRESS SIZE AND DESIRED FIRMNESS

You can't go wrong with this bed! Take it camping or use it for out of town guests. Our best selling Classic Downy Bed is versatile and perfect for both in-home and camping. The wave beam construction creates a uniform sleeping surface that is guaranteed to give you a good night's rest wherever you are. Plush flocking provides a luxurious sleeping surface while keeping sheets in place. It's also easy to clean and waterproofed for camping use. The Classic Downy Bed offers retailers and consumers the best value for their money at an opening price point.

### PLUSH FLOCKED TOP FOR COMFORT

- 2-in-1 valve has extra-wide openings for fast inflating and deflating
- Conventional mattress sizes (L x W) for more sleeping area and a better fit for sheets
- 8 3/4" (22cm) mattress thickness for extra soft comfort



## AIRBED only

		Approximate Inflated Size	Case Pack	Case Weight
68950 / E	Cot Size	30" x 75" x 8 3/4" 76cm x 1.91m x 22cm	6 ea	31.2 lb (14.2 kg)
68757 / E	Twin	39" x 75" x 8 3/4" 99cm x 1.91m x 22cm	4 ea	26.1 lb (11.9 kg)
68758 / E	Full	54" x 75" x 8 3/4" 1.37m x 1.91m x 22cm	3 ea	26.0 lb (11.8 kg)
68759 / E	Queen	60" x 80" x 8 3/4" 1.52m x 2.03m x 22cm	3 ea	30.6 lb (13.9 kg)
68755 / E	King	72" x 80" x 8 3/4" 1.83m x 2.03m x 22cm	2 ea	23.9 lb (10.9 kg)

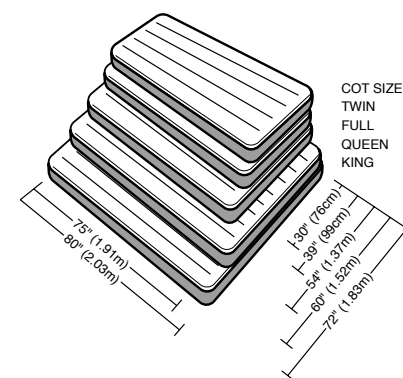

## AIRBED SET

Includes two I-beam pillows  
17" x 11" x 3 1/2" (43cm x 28cm x 9cm)  
and a #68612 Double-Quick air pump

	Approximate Inflated Size	Hand Pump	Case Pack	Case Weight
68765 / E Queen	60" x 80" x 8 3/4" 1.52m x 2.03m x 22cm	68612	3 ea	34.4 lb (15.7 kg)



# PILLOW REST CLASSIC BED



Wave Beam Construction

Built-in AC Electric Pump

Built-in pillow for added convenience

For those who need a pillow but lack the space to carry one, this luxurious flocked bed is the answer. The waterproof and stain resistant surface makes it easy to keep clean while providing the soft comfort of home.

### BUILT-IN COMFORT

- Flocked sleeping surface for extra comfort
- A built-in pillow provides bed-like comfort
- Mattress is raised 9" (23cm) from the floor for convenience
- 3-in-1 valve on "Airbed Only" series has extra-wide openings
- Inflated dimensions fit standard sheet sizes

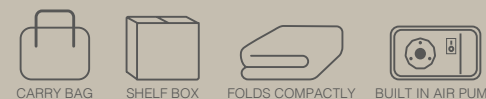

CARRY BAG SHELF BOX FOLDS COMPACTLY BUILT IN AIR PUMP

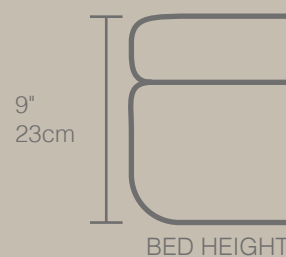

AC Electric Pump INFLATING TIMES*	
TWIN	1 Minute
FULL	1 1/2 Minutes
QUEEN	1 3/4 Minutes

\*INFLATING TIME VARIES BY MATTRESS SIZE AND DESIRED FIRMNESS

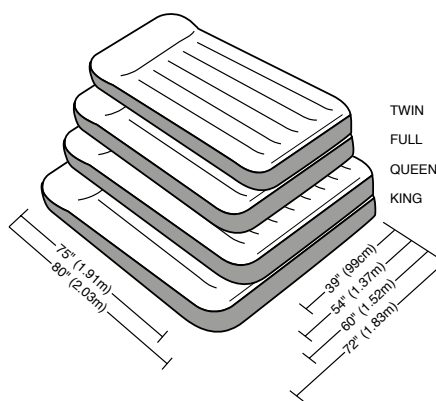

### AIRBED

only	Approximate Inflated Size	Case Pack	Case Weight
66767 / E Twin	39" x 75" x 9" 99cm x 1.91m x 23cm	4 ea	29.9 lb (13.6 kg)
66768 / E Full	54" x 75" x 9" 1.37m x 1.91m x 23cm	3 ea	29.9 lb (13.6 kg)
66769 / E Queen	60" x 80" x 9" 1.52m x 2.03m x 23cm	3 ea	35.2 lb (16.0 kg)
66770 / E King	72" x 80" x 9" 1.83m x 2.03m x 23cm	2 ea	27.9 lb (12.7 kg)

### AIRBED

with Built-in Electric Pump	Approximate Inflated Size	Built-in Pump	Case Pack	Case Weight
66775E Twin	39" x 75" x 9" 99cm x 1.91m x 23cm	110 - 120V 220 - 240V	4 ea	38.4 lb (17.5 kg)
66779 Full	54" x 75" x 9" 1.37m x 1.91m x 23cm	110 - 120V 220 - 240V	3 ea	36.2 lb (16.5 kg)
66776E Queen	60" x 80" x 9" 1.52m x 2.03m x 23cm	110 - 120V 220 - 240V	3 ea	42.1 lb (19.2 kg)
66780 King	72" x 80" x 9" 1.83m x 2.03m x 23cm	110 - 120V 220 - 240V	2 ea	27.9 lb (12.7 kg)



# CAMPING MATS

A quick, simple and lightweight sleeping solution while camping. Wave beam construction for a uniform sleeping surface. Intex camping mats provide comfort and durability for outside conditions.

## LAMINATED FABRIC TOPS FOR DURABILITY

- Laminated vinyl to withstand the elements
- Each mat has a unique construction that helps provide more comfort to campers
- Topped with fabric to ensure sleeping comfort



SHELF BOX FOLDS COMPACTLY

#68797



#68799



#68798

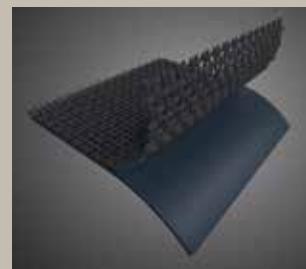

Puncture-resistant 2-ply laminate

# COT SIZE CAMP BED

Find your perfect sleep solution for the outdoors with the new Cot Size Camp Bed. Made with rugged laminated PVC. This bed is designed to fit easily on cots or inside tents. This lightweight and portable mat provides a smooth and comfortable sleeping surface in any outdoor environment.



SHELF BOX FOLDS COMPACTLY



## CAMPING

Mat	Approximate Inflated Size	Case Pack	Case Weight
68797 / E	26½" x 72½" x 6¾" 67cm x 1.84m x 17cm	6 ea	19.5 lb (8.9 kg)
68798 / E	28½" x 74½" x 8" 72cm x 1.89m x 20cm	6 ea	26.0 lb (11.8 kg)
68799 / E	50" x 76" x 9½" 1.27m x 1.93m x 24cm	3 ea	22.6 lb (10.3 kg)

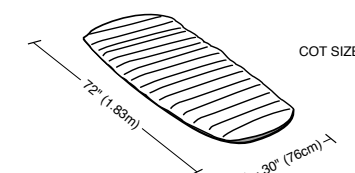
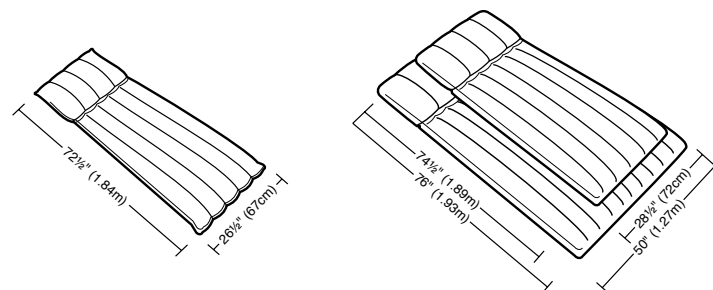

COT SIZE

## CAMPING

Bed	Approximate Inflated Size	Case Pack	Case Weight
68708 / E Cot Size	30" x 72" x 4" (76cm x 1.83m x 10cm)	6 ea	27.5 lb (12.5 kg)





# SUPER-TOUGH™ AIRBED

Bright, bold and compact, the Super-Tough™ airbed provides campers with the ultimate camping experience.

The Super-Tough™ PVC and polyester laminate create a smooth, yet strong sleeping surface, guaranteed to give campers a great night's sleep. High-strength Fiber-Tech™ fibers make up the inner construction and are combined with a puncture resistant laminated surface to make this camping airbed very strong, comfortable, and long-lasting.

For the ultimate in convenience, the Super-Tough™ bed is also available with a built-in 6 C-cell battery pump.

## STRENGTH, LIGHT-WEIGHT, CONVENIENCE & COMFORT

- Fiber-Tech™ interior construction
- Bright and bold outdoor color
- Super-Tough™ laminated exterior surfaces

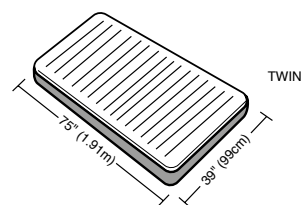
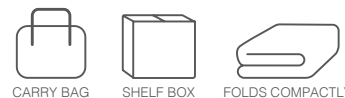

### AIRBED

with Built-in 6 C-Cell Battery Pump

	Approximate Inflated Size	Case Pack	Case Weight
64791 / E Twin	39" x 75" x 8" 99cm x 1.91m x 20cm	3 ea	24.6 lb (11.2 kg)



Fiber-Tech™ Technology

Perfect for camping with 6 C-cell batteries (not included)

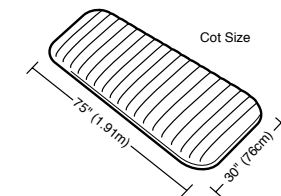

# ROLL 'N GO™ BED

The Roll 'N Go™ bed offers the perfect ultra light weight sleep solution for your next camping trip.

## ULTIMATE OUTDOOR BED WITH PUMP

- Fiber-Tech™ interior construction
- Eco-friendly TPU laminated fabric – phthalate-free material
- Hand-held high output lightweight manual air pump
- Duffel bag with handle included



This PVC Free airbed is constructed of laminated TPU, which means it is:

- Super Tough – Softens up the rough outdoors with a very durable, eco-friendly material
- Strong Support System – Inflates up to three times the pressure of a regular PVC junior-twin airbed for a firmer sleeping surface
- Ultra Lightweight – Weighs approximately one fourth less than a common junior-twin PVC constructed airbed



## MAXIMUM DURABILITY

The strong TPU (Thermoplastic Polyurethane) laminated material and innovative Fiber-Tech™ inner construction transform the toughest ground into a refreshing night's sleep. It retains elasticity in temperature as low as -4° F/-20° C.

Made of TPU – A PVC-free eco-friendly material



### AIRBED

with Hand Pump

	Approximate Inflated Size	Hand Pump	Case Pack	Case Weight
64780 / E Cot Size	30" x 75" x 5" 76cm x 1.91m x 13cm	68612	4 ea	20.9 lb (9.5 kg)



Fiber-Tech™ Technology

Hand Pump (#68612)



# AIR FURNITURE

Style. Color. Fun.  
Cool Living Spaces with Intex.

Intex brings to you an exciting and vibrant line of air furniture for any age, any setting and any season! With great colors and design, whether for the indoors or the outdoors, Intex has something for everyone. Decorate your room with Intex!



## BEANLESS BAG™ CHAIR ASSORTMENT

A great bean bag without the hassle of bean bag inserts and slipcovers. Just unfold and inflate, and in minutes you have a super soft bean bag that is perfect for lounging, studying, or watching movies. Vivid colors will brighten up any room. Comes in an assortment of three bright and vivid colors: Magenta Pink, Lime Green, or Lilac Purple.

### PERFECTLY PORTABLE BEANLESS BAG™

- Available in magenta pink, lime green and lilac purple
- Folds compactly for storage
- Shelf box

Item	Approximate Inflated Size	Case Pack	Case Weight
68569NP / EP	42" x 41" x 27" 1.07m x 1.04m x 69cm	6 ea, asst	33.6 lb (15.3 kg)



U.S. Patent No. 6,152,530



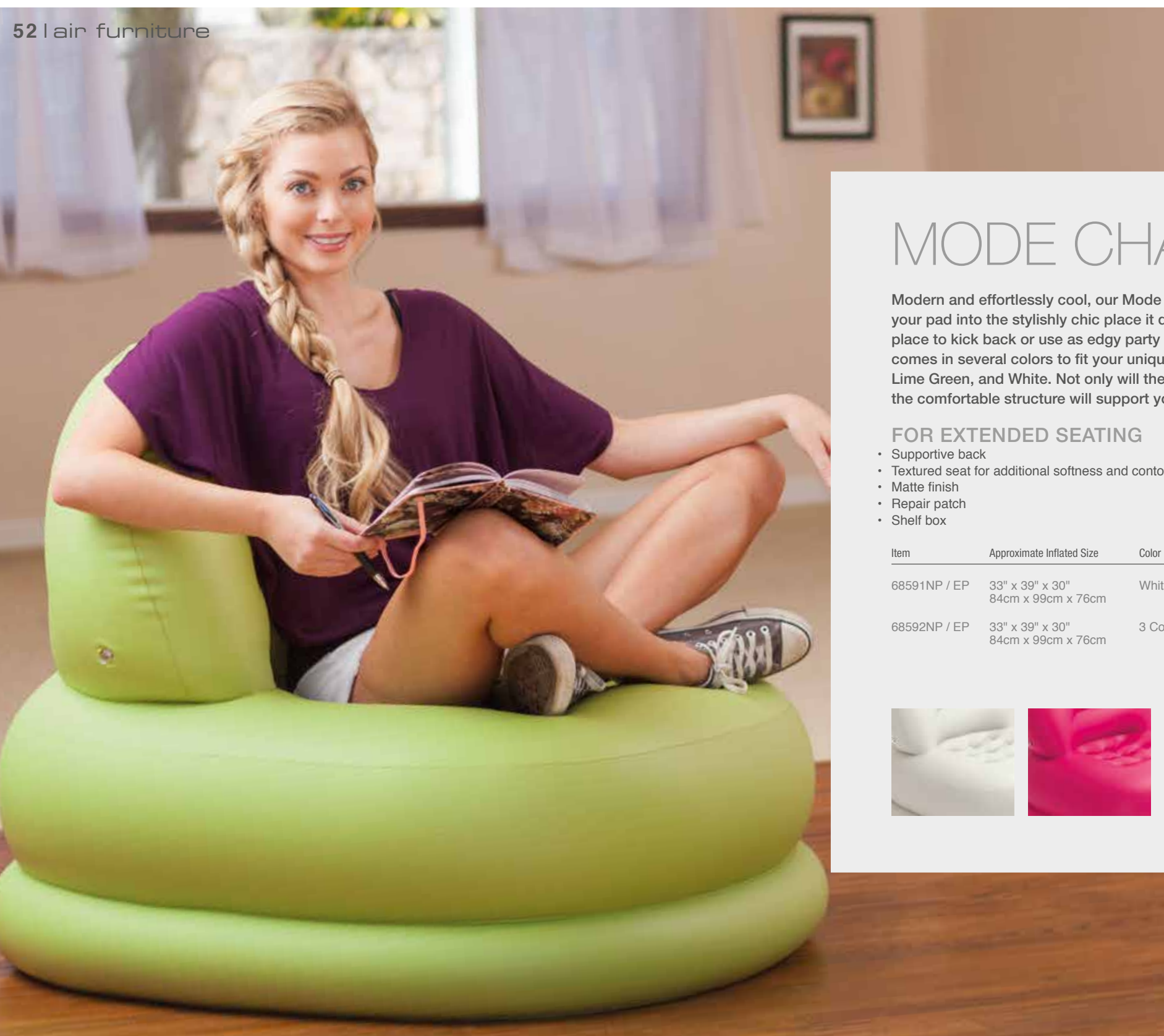

## MODE CHAIR

Modern and effortlessly cool, our Mode Chair is a surefire way to turn your pad into the stylishly chic place it deserves to be. It's the best place to kick back or use as edgy party decor. The innovative design comes in several colors to fit your unique style including Magenta Pink, Lime Green, and White. Not only will the colors support your style but the comfortable structure will support you, in style.

### FOR EXTENDED SEATING

- Supportive back
- Textured seat for additional softness and contoured fit
- Matte finish
- Repair patch
- Shelf box

Item	Approximate Inflated Size	Color	Case Pack	Case Weight
68591NP / EP	33" x 39" x 30" 84cm x 99cm x 76cm	White	6 ea	29.2 lb (13.3 kg)
68592NP / EP	33" x 39" x 30" 84cm x 99cm x 76cm	3 Colors	6 ea, asst	29.2 lb (13.3 kg)

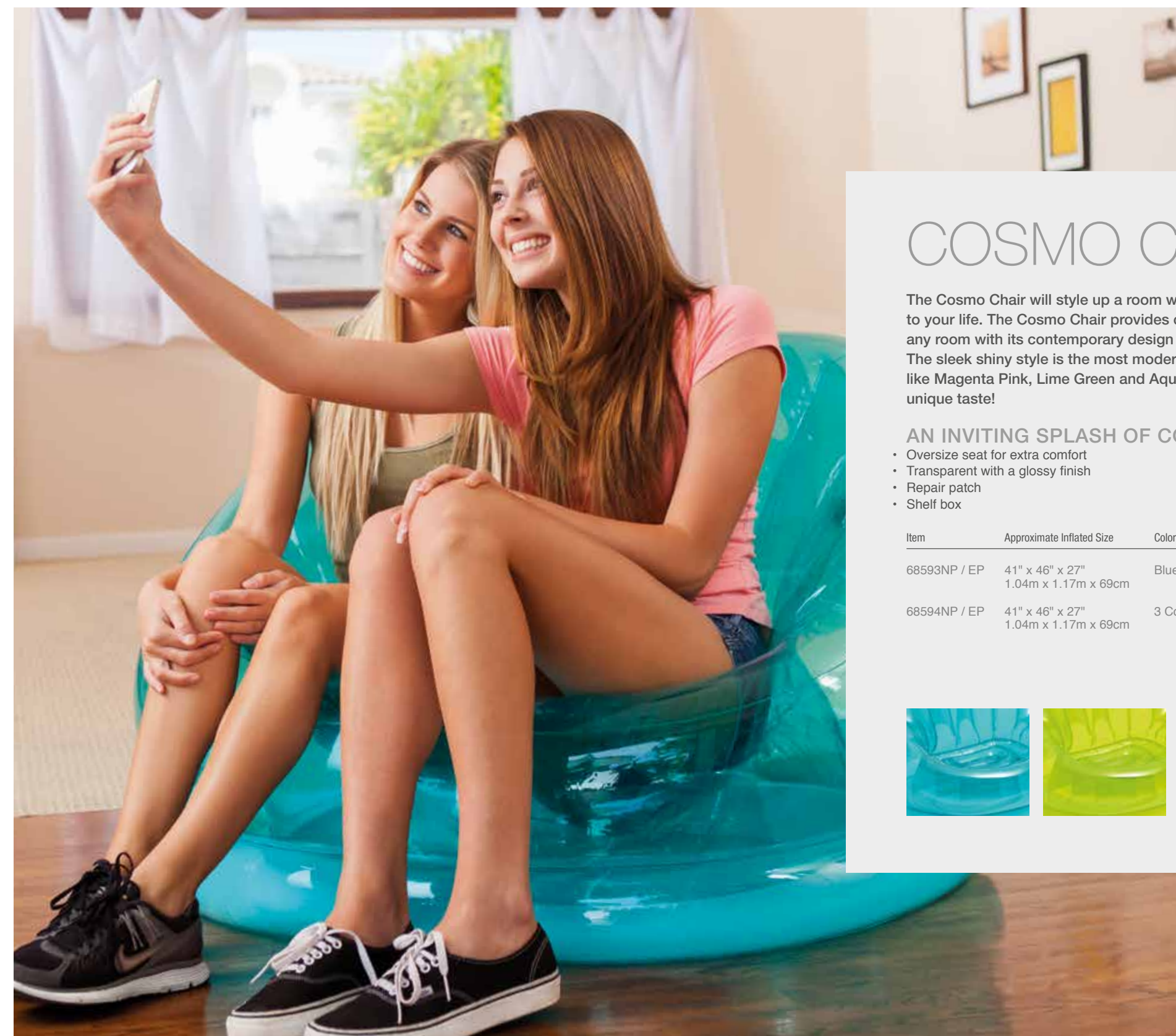
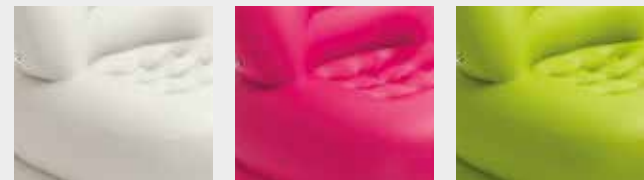

## COSMO CHAIR

The Cosmo Chair will style up a room with ease and bring new excitement to your life. The Cosmo Chair provides cool comfort at home, spicing up any room with its contemporary design that looks and feels stylish. The sleek shiny style is the most modern way to chill out, and colors like Magenta Pink, Lime Green and Aqua Blue are perfect to fit your unique taste!

### AN INVITING SPLASH OF COLOR AND COMFORT

- Oversize seat for extra comfort
- Transparent with a glossy finish
- Repair patch
- Shelf box

Item	Approximate Inflated Size	Color	Case Pack	Case Weight
68593NP / EP	41" x 46" x 27" 1.04m x 1.17m x 69cm	Blue	3 ea	19.4 lb (8.8 kg)
68594NP / EP	41" x 46" x 27" 1.04m x 1.17m x 69cm	3 Colors	3 ea, asst	19.4 lb (8.8 kg)







## CAFÉ CHAISE CHAIR

Stunning and eye-catching, this Café Chaise Chair adds flair to any room! Paired with an ottoman, the advanced structural design provides an exceptionally comfortable seat regardless of your height.

### COLORFUL CUSHY LUXURY

- Combo valve has extra-wide openings for fast inflating and deflating
- Available in lilac purple, sky blue, and sunny orange
- Folds compactly for storage
- Shelf box

Item		Approximate Inflated Size	Case Pack	Case Weight
68572NP / EP	Chair	41" x 43" x 28" 1.04m x 1.09m x 71cm	3 ea, asst	20.9 lb (9.5 kg)
	Ottoman	25" x 11" 64cm x 28cm		



## BEANLESS BAG™ CHAIR

Intex completes the Beanless Bag™ Chair line with the introduction of a warm, neutral color combined with our revolutionary corduroy texture flocking! Its elegant and luxurious look and feel will add a new dimension to any room!

### PERFECTLY PORTABLE BEANLESS BAG™

- Folds compactly for storage
- Shelf box

Item	Approximate Inflated Size	Case Pack	Case Weight
68579NP / EP	42" x 41" x 27" 1.07m x 1.04m x 69cm	6 ea	34.3 lb (15.6 kg)

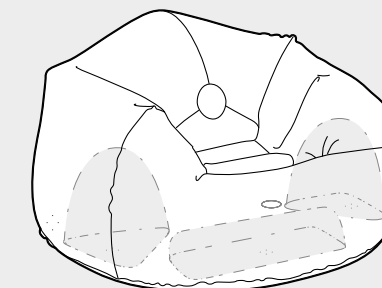

Beanless Bag™ chair inner structure  
U.S. Patent No. 6,152,530





## PULL-OUT CHAIR NEW STRUCTURE

A perfect chair that transforms into a single bed! Not only is it comfortable, it's conveniently versatile. Ideal for college dorms, guest bedrooms and even on the road.

### STURDY COMFORT

- 2-in-1 valve has extra-wide openings for fast inflating and deflating
- Folds compactly for storage
- Cup holder for refreshments
- Shelf box

### 2-in-1 Valve

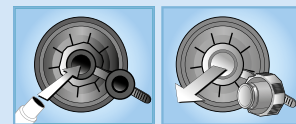

Extra-wide valve openings for fast inflating and deflating

Item	Approximate Inflated Size	Case Pack	Case Weight
68565NP / EP	42" x 87" x 26" 1.07m x 2.21m x 66cm	2 ea	22.2 lb (10.1 kg)



## PULL-OUT SOFA NEW STRUCTURE

A versatile sofa that offers an affordable and comfortable sleeping solution for any home. It is quick and easy to inflate and will seat or sleep two people.

### PRACTICAL & VERSATILE

- 2-in-1 valve has extra-wide openings for fast inflating and deflating
- 3 quick inflation and deflation valves
- Comfortable backrest and armrest
- Folds compactly for storage
- Two cup holders
- Shelf box

### 2-in-1 Valve

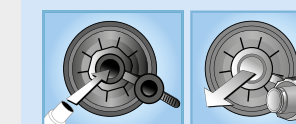

Extra-wide valve openings for fast inflating and deflating

Item	Approximate Inflated Size	Case Pack	Case Weight
68566NP / EP	76" x 87" x 26" 1.93m x 2.21m x 66cm	2 ea	41.0 lb (18.7 kg)







## ULTRA LOUNGE

Attractive contours from any angle, the beauty of this lounge chair is matched only by its comfort. Contact surfaces on the top and sides are lined with flocking for the touch of luxury. The side cup holder is just as indispensable here as in your favorite sports car.

### RELAX AT HOME WITH OUR ULTRA LOUNGE

- 2-in-1 valve has extra-wide openings for fast inflating and deflating
- Convenient cup holder for refreshments
- Folds compactly for storage
- Shelf box

Item		Approximate Inflated Size	Case Pack	Case Weight
68564NP / EP	Chair	39" x 51" x 30" 99cm x 1.30m x 76cm	4 ea	31.5 lb (14.3 kg)
	Ottoman	25" x 11" 64cm x 28cm		



Comfortable seating with side cup holder



## CORNER SOFA

A corner sofa can be a fantastic addition to any living room. This beautifully designed piece is luxurious yet convenient. Create an intimate conversation area or an expansive seating arrangement for family and friends. Casual and comfortable, this sofa is designed with deep seats and wide armrests, and sleekly streamlined for sophisticated appeal.

### SPACIOUS COMFORT AND CONVENIENCE

- Quality-tested waterproof flocked surface for a luxurious feel
- 2-in-1 valve with extra-wide openings for fast inflating and deflating
- Neutral color to suit any home decor
- Repair patch
- Shelf box

#### 2-in-1 Valve

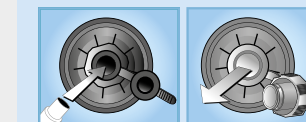

Extra-wide valve openings for fast inflating and deflating

Item	Approximate Inflated Size	Case Pack	Case Weight
68575NP / EP	101" x 80" x 30" 2.57m x 2.03m x 76cm	1 ea	28.6 lb (13.0 kg)







## ACCENT CHAIR NEW

The Intex Accent Apple Green Chair / Club Taupe Grey Chair is a combination of comfort, simplicity and style - Enjoy a movie or relax outside in the sun.

### GREAT FOR INDOOR AND OUTDOOR

- removable backrest
- 2-in-1 valve has extra-wide openings for fast inflating and deflating
- Cup holder for convenience
- Additional chamber fills with water to anchor chair
- Shelf box

### 2-in-1 Valve

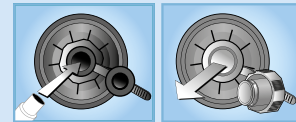

Extra-wide valve openings for fast inflating and deflating

Item	Approximate Inflated Size	Color	Case Pack	Case Weight
68586NP / EP	38" x 42" x 28" 97cm x 1.07m x 71cm	Green	3 ea	23.6 lb (10.7 kg)
68587NP / EP	38" x 42" x 28" 97cm x 1.07m x 71cm	Grey	3 ea	23.6 lb (10.7 kg)

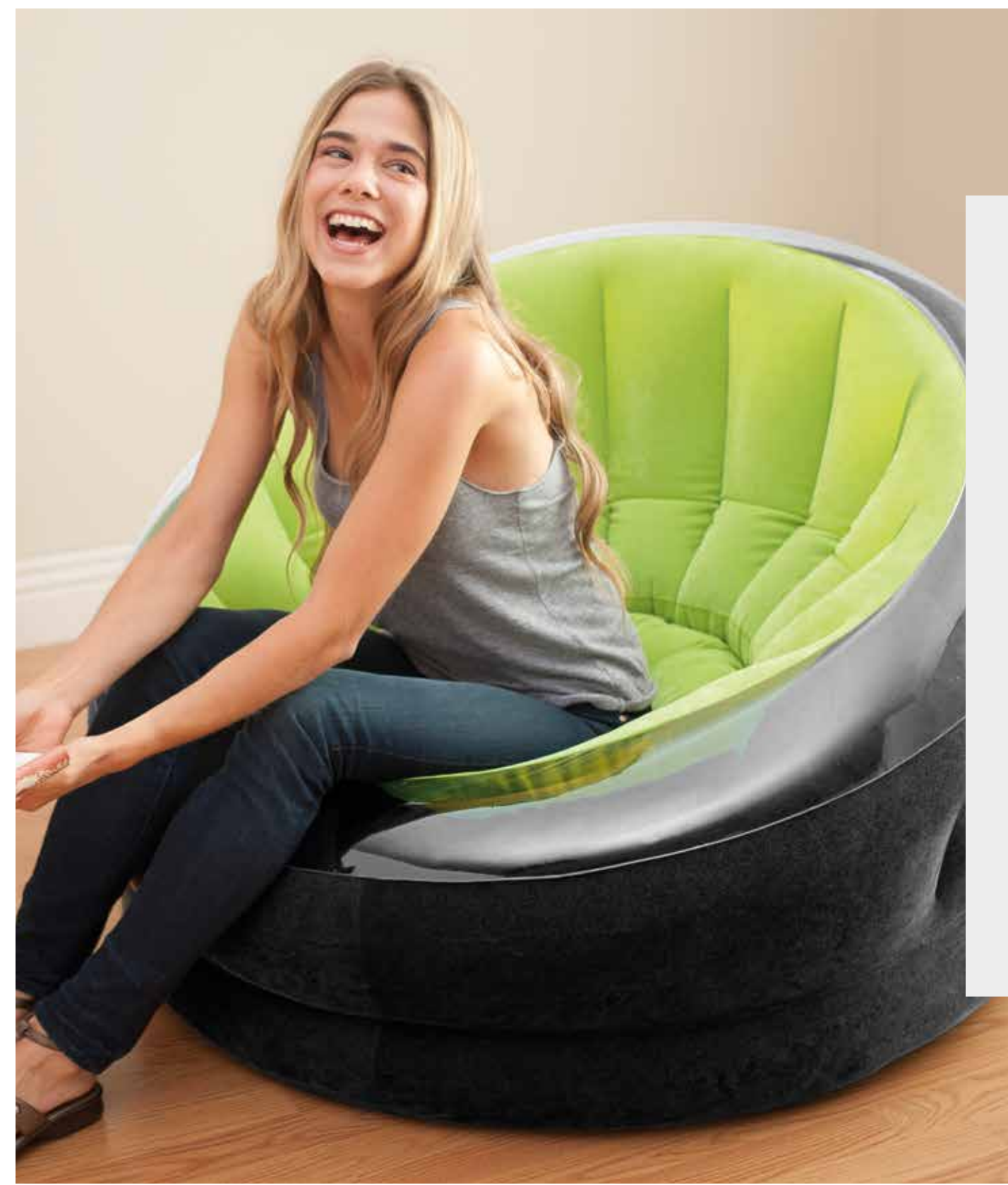

## EMPIRE CHAIR

Modern, sophisticated and endlessly comfortable best describes this new addition to our line of inflatable chairs. In sunny orange, pink or lime green with an innovative transparent trim, this chair is the perfect combination of form and function. It's ideal for teens, college students and young professionals!

### AN INVITING SPLASH OF COLOR AND COMFORT

- Extra strong laminated bottom for better durability
- Great for both indoors and outdoors
- Puncture-resistant 2-ply reinforced laminated bottom
- Additional chamber fills with water to anchor chair
- Shelf box

Item	Approximate Inflated Size	Color	Case Pack	Case Weight
68581NP / EP	44" x 43" x 27" 1.12m x 1.09m x 69cm	Green	3 ea	21.7 lb (9.9 kg)
68582NP / EP	44" x 43" x 27" 1.12m x 1.09m x 69cm	3 Colors	3 ea, asst	21.7 lb (9.9 kg)







## MEGA LOUNGE

What makes this a mega lounge? Keeping multi-function in mind, this lounge is designed for the ultimate comfort experience. Its long seat will let you sprawl out when you are gaming or watching TV. The included cup holder lets you keep snacks or a drink at arm's length.

### PERFECT FOR RELAXING AT HOME

- Sleek design for a modern style
- Grooved and contoured shape for a natural fit and added comfort
- Long seat perfect for extending legs
- 1 cup holder
- 2-in-1 valve with extra wide openings for fast inflation and deflation
- Puncture-resistant 2-ply reinforced laminated bottom
- Additional chamber fills with water to anchor lounge
- Repair patch
- Shelf box

Item	Approximate Inflated Size	Case Pack	Case Weight
68585NP / EP	32" x 68" x 36" 81cm x 1.73m x 91cm	3 ea	25.0 lb (11.4 kg)



## SPLASH LOUNGE

The Splash Lounge will look gorgeous indoors or outdoors. It's a great casual addition to any room. The reinforced bottom also makes it durable for lounging on the patio, yard or poolside.

### PERFECTLY PORTABLE LOUNGE

- Extra strong laminated bottom for better durability
- Great for both indoors and outdoors
- Puncture-resistant 2-ply reinforced laminated bottom
- Additional chamber fills with water to anchor lounge
- Shelf box

Item	Approximate Inflated Size	Case Pack	Case Weight
68880NP / EP	33" x 67" x 32" 84cm x 1.70m x 81cm	3 ea	21.5 lb (9.8 kg)



Soft Flocked Surface





## ULTRA DAYBED LOUNGE NEW STRUCTURE

The Ultra Daybed Lounge invites you to relax, soak up the sun and hang out with friends. It's an elegant addition to any room, patio or yard as the reinforced bottom and soft flocking make it versatile enough for both indoors and outdoors.

### RELAX AT HOME WITH OUR ULTRA DAYBED LOUNGE

- Backrest for extra comfort
- Extra strong laminated bottom for better durability
- Great for both indoors and outdoors
- Puncture-resistant 2-ply reinforced laminated bottom
- Additional chamber fills with water to anchor lounge
- Shelf box

Item	Approximate Inflated Size	Case Pack	Case Weight
68881NP / EP	75" (D) x 20" (H) 1.91m x 51cm	2 ea	29.5 lb (13.4 kg)

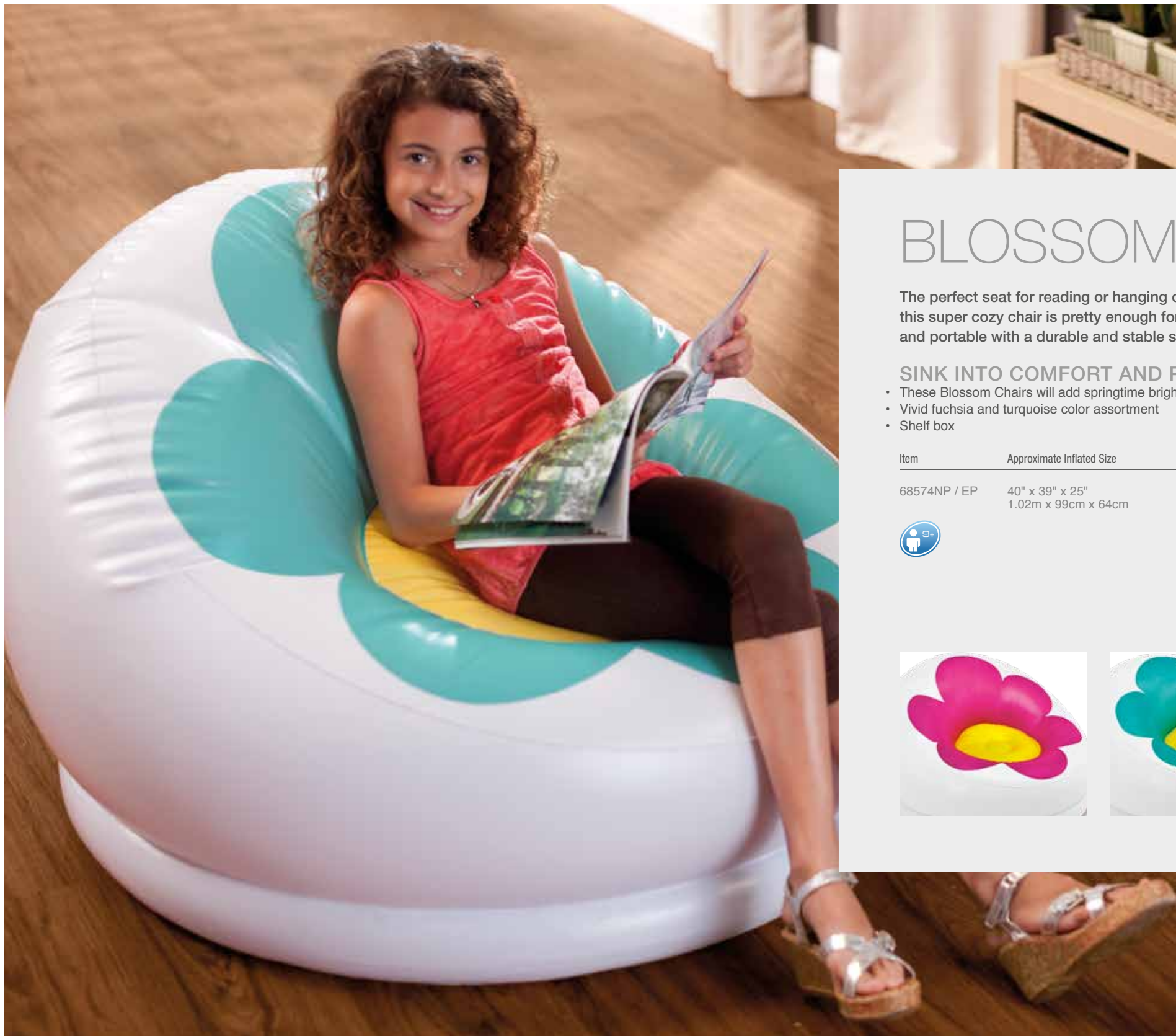

## BLOSSOM CHAIR

The perfect seat for reading or hanging out and chatting with friends, this super cozy chair is pretty enough for any girl's room! It's light and portable with a durable and stable structure.

### SINK INTO COMFORT AND PRETTINESS

- These Blossom Chairs will add springtime brightness to any girl's room
- Vivid fuchsia and turquoise color assortment
- Shelf box

Item	Approximate Inflated Size	Case Pack	Case Weight
68574NP / EP	40" x 39" x 25" 1.02m x 99cm x 64cm	6 ea, asst	27.1 lb (12.3 kg)





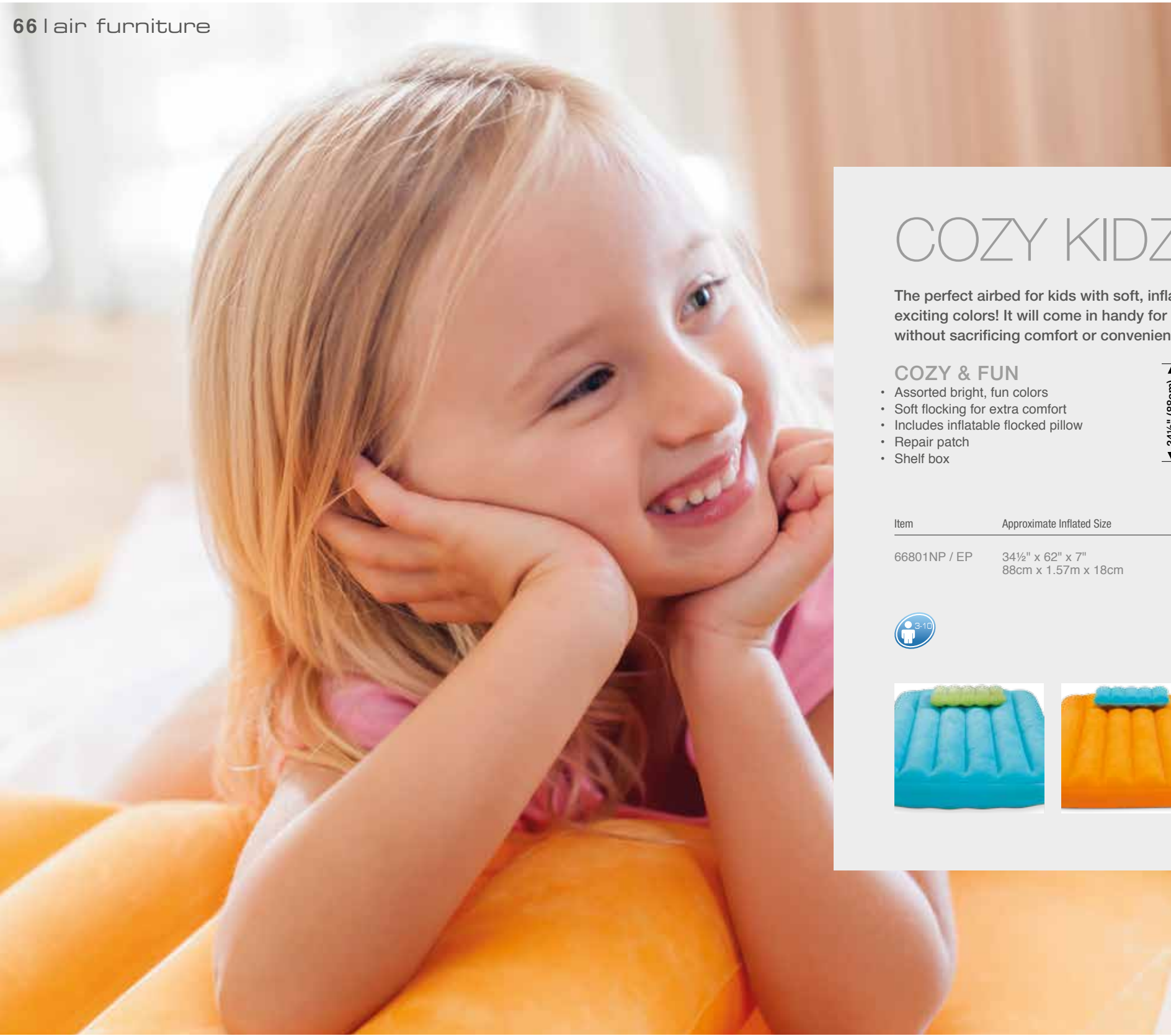

## COZY KIDZ™ AIRBED

The perfect airbed for kids with soft, inflatable pillows in three fun and exciting colors! It will come in handy for sleepovers, nap time and travel, without sacrificing comfort or convenience!

### COZY & FUN

- Assorted bright, fun colors
- Soft flocking for extra comfort
- Includes inflatable flocked pillow
- Repair patch
- Shelf box

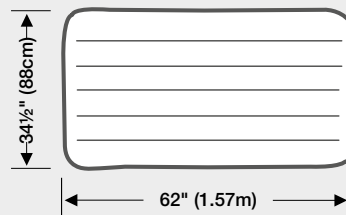

Item	Approximate Inflated Size	Case Pack	Case Weight
66801NP / EP	34 1/2" x 62" x 7" 88cm x 1.57m x 18cm	6 ea, asst	27.0 lb (12.3 kg)

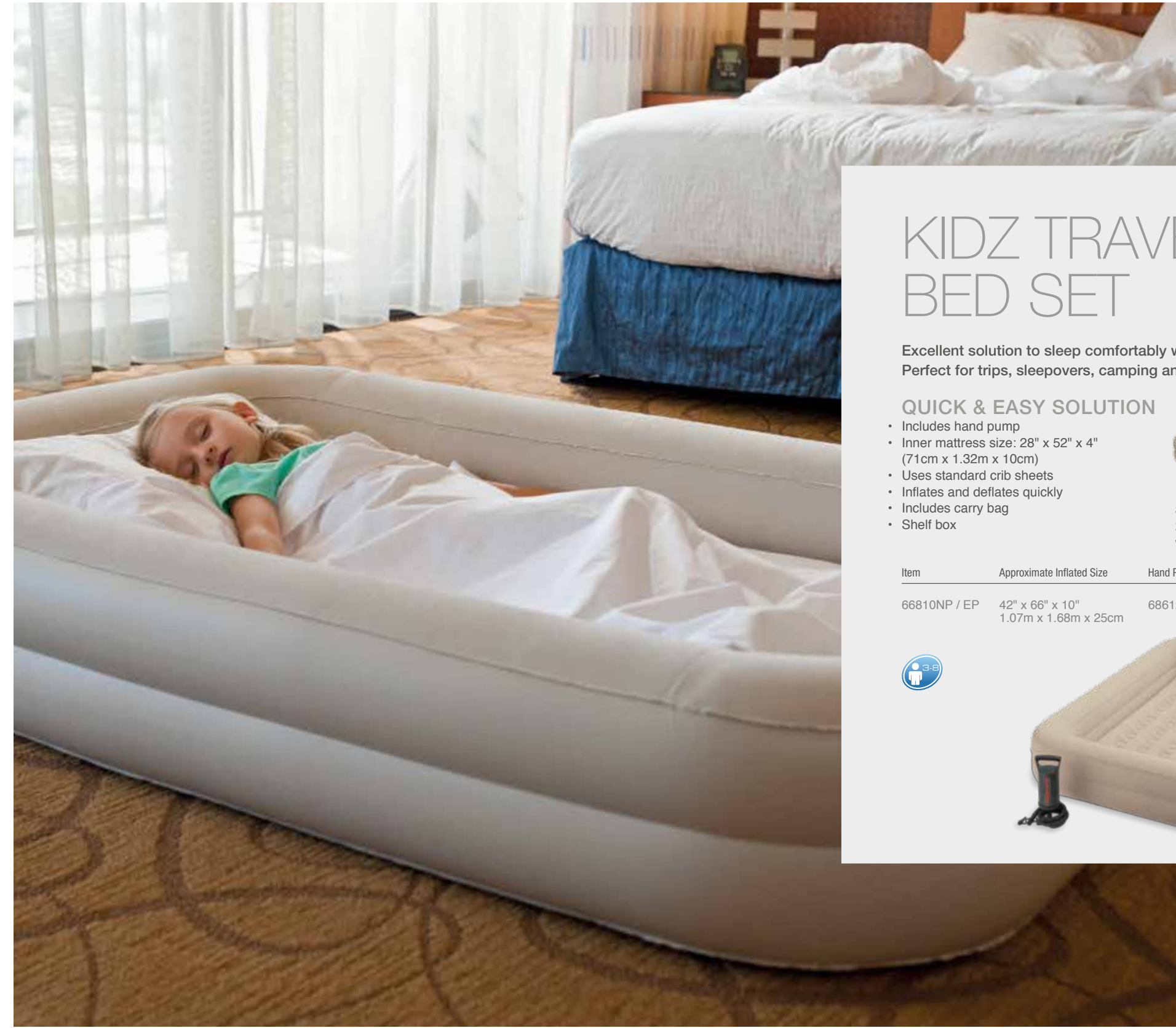

## KIDZ TRAVEL BED SET

Excellent solution to sleep comfortably when away from home. Perfect for trips, sleepovers, camping and even for nap times!

### QUICK & EASY SOLUTION

- Includes hand pump
- Inner mattress size: 28" x 52" x 4" (71cm x 1.32m x 10cm)
- Uses standard crib sheets
- Inflates and deflates quickly
- Includes carry bag
- Shelf box



Sleep area is  
28" x 52" (71cm x 1.32m)  
with soft frame surround

Item	Approximate Inflated Size	Hand Pump	Case Pack	Case Weight
66810NP / EP	42" x 66" x 10" 1.07m x 1.68m x 25cm	68612	3 ea	29.0 lb (13.2 kg)







# ACCESSORIES

## PILLOWS

### #68678NP / EP Kidz Travel Pillows



- Frog: 11" x 12" x 3" (28cm x 30cm x 8cm)
- Cat: 12" x 11" x 3" (30cm x 28cm x 8cm)
- Child-friendly designs
- Soft flocking for extra comfort
- Pegable box
- 36 ea, asst 7.4 lb (3.4 kg)



### #68675 / E Travel Pillow

- 14" x 12" x 4" (36cm x 30cm x 10cm)
- Black super soft flocked surface
- Perfect for those long plane and car trips
- Contoured for neck support
- Folds up for easy travel
- Pegable box
- 36 ea, 8.3 lb (3.8 kg)



### #68672 / E Downy Pillow

- 17" x 11" x 3½" (43cm x 28cm x 9cm)
- I-beam construction
- Pegable box
- 24 ea, 8.1 lb (3.7 kg)



### #68676NP / EP Kidz Pillows



- 17" x 11" x 3½" (43cm x 28cm x 9cm)
- Available in Sunny Orange, Sky Blue and Lime Green
- Pegable box
- 24 ea, asst 8.1 lb (3.7 kg)



### #68670 / E 2-in-1 Pillow Cushion

- 23" x 14" x 5" (58cm x 36cm x 13cm)
- Super plush flocked surface for comfort and convenience
- Superior design for lumbar support
- Pegable box
- 12 ea, 8.4 lb (3.8 kg)



## AIRBED COVER

Add a layer of comfort to your airbed with our Intex fitted polyester bed covers. The all-new fitted bed covers adds a touch of home for your guests or your next outdoor adventure. Bed covers comes in both Twin and Queen sizes. Ideal for mid-rise to double high beds.

### #69641 / E AIRBED COVER



- Fits twin size airbed up to 18" (46cm) high
- Elegant quilted pattern
- 100% Polyester
- 200 thread count
- 75D x 75D x 200T
- 39" W x 75" L x 4" H (99cm x 1.91m x 10cm)
- 3 ea, 4.7 lb (2.1 kg)

### #69643 / E AIRBED COVER



- Fits queen size airbed up to 22" (56cm) high
- Elegant quilted pattern
- 100% Polyester
- 200 thread count
- 75D x 75D x 200T
- 60" W x 80" L x 4" H (1.52m x 2.03m x 10cm)
- 3 ea, 6.8 lb (3.1 kg)



#69643

#69641



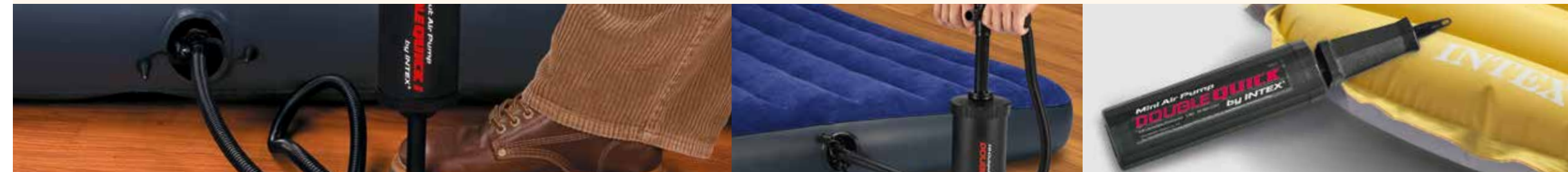

## MANUAL PUMPS

### #68612 / E Double Quick I Hand Pump

- 11½" (29cm)
- 3 interconnecting nozzles with hose
- TUV RL approved
- Inflates on both up and down strokes
- Shelf box

12 ea, 11.1 lb (5.0 kg)



### #68614 / E Double Quick II Hand Pump

- 2 times the air flow of #68612
- 14" (36cm)
- 3 interconnecting nozzles with hose
- TUV RL approved
- Inflates on both up and down strokes
- Shelf box

4 ea, 6.1 lb (2.8 kg)



### #68605 / E Double Quick III S Hand Pump

- 3 times the air flow of #68612
- 14½" (37cm)
- 3 interconnecting nozzles with hoses
- TUV RL approved
- Inflates and deflates
- Pumps on up and down strokes
- Shelf box

3 ea, 6.5 lb (3.0 kg)



### #68615 / E Double Quick III Hand Pump

- 3½ times the air flow of #68612
- 19" (48cm)
- TUV RL approved
- Large nozzle threaded for athletic ball inflating needle (one included)
- Inflates athletic balls up to 8 psi
- Inflates and deflates
- Pumps on up and down strokes
- Shelf box

3 ea, 9.0 lb (4.1 kg)



U.S. Patent  
No. 6,299,420

### #69613 / E Double Quick Mini Hand Pump

- 11½" (29cm)
- TUV RL approved
- Inflates on fore and back strokes

24 ea, 7.3 lb (3.3 kg)



### #69611 / E Bellows Foot Pump

- 11" (28cm)
- TUV RL approved
- Inflates and deflates
- Shrink wrapped with litho label

6 ea, 8.4 lb (3.8 kg)



### #68610 / E Giant Bellows Foot Pump

- 50% more air flow than of #69611
- 12" (30cm)
- TUV RL approved
- Inflates and deflates
- Shelf box

6 ea, 13.6 lb (6.2 kg)







# ACCESSORIES

## ELECTRIC PUMPS

These Quick-Fill™ electric pumps have a sleek, aerodynamic design that fits perfectly in the palm of your hand, yet still inflate even the largest of inflatables in a breeze.

### Quick-Fill™ AC/DC Electric Pump features include:

- 3 interconnecting nozzles
- 12V DC & AC power adapter for easy Outdoor and Indoor use
- ETL approved (110-120V)
- CE approved (220-240V)
- Shelf box



#66631 (110-120V)  
#66632 (220-240V)

- Outdoor & Indoor Use
- AC or Car
- Nozzles Fit Any Valve Size

### Quick-Fill™ DC Electric Pump features include:

- 3 interconnecting nozzles
- Plug into 12V DC automobile cigarette lighter or 12V DC accessory outlet
- ETL approved
- CE, GS approved
- Shelf box



#66626 (12V)

- Outdoor Use
- 12V Car Adapter
- Nozzles Fit Any Valve Size

### Quick-Fill™ AC Electric Pump features include:

- 3 interconnecting nozzles
- Thermo protector incorporated for safety
- ETL approved (110-120V)
- CE, GS approved (220-240V)
- Shelf box



#66619 (110-120V)  
#66620 (220-240V)

- Indoor Use
- 110-120V AC 220-240V AC
- Nozzles Fit Any Valve Size

### Quick-Fill™ High PSI Indoor/outdoor Electric Pump features include:

- 3 interconnecting nozzles with hose
- For both indoor and outdoor use - plugs into cigarette lighter or household electrical outlet
- 2-speed switch
- Inflates athletic balls up to 12 psi
- Detachable DC cigarette cord
- ETL approved (110-120V)
- CE, GS approved (220-240V)
- Shelf box



#68608 (110-120V)  
#68609 (220-240V)

- Outdoor & Indoor Use
- AC or Car
- Nozzles Fit Any Valve Size



#68638

### Quick-Fill™ BATTERY Pump features include:

- 24% more air flow than previous version (#68639)
- Operates on 6 C-cell size batteries
- 3 interconnecting nozzles
- CE approved
- Shelf box

- Outdoor & Indoor Use
- 6 C Batteries Required (not included)
- Nozzles Fit Any Valve Size

### Quick-Fill™ RECHARGEABLE Pump features include:

- 3 interconnecting nozzles
- A 12V DC power adapter for vehicle charging and a household AC power adapter for home charging
- 12V DC to inflate and deflate while recharging
- Automatic over-charge cut off for safety protection
- New shape with easy carry handle
- ETL approved (110-120V)
- CE approved (220-240V)
- Shelf box



#66621 (110-120V)  
#66622 (220-240V)

- Built-in Rechargeable Battery
- AC or Car
- Outdoor & Indoor Use
- Nozzles Fit Any Valve Size

### Quick-Fill™ AC Electric Pump features include:

- 3 interconnecting nozzles with hose
- Thermo protector incorporated for safety
- New shape with easy carry handle
- ETL approved (110-120V model)
- CE, GS approved (220-240V model)
- Shelf box



#66623 (110-120V)  
#66624 (220-240V)

- Indoor Use
- 110-120V AC 220-240V AC
- Nozzles Fit Any Valve Size

Item #	Voltage			Disposable Batteries	Outdoor Use	Accordion Hose with 3 Nozzles	3 Interconnecting Nozzles	Max. Air Flow (L/min)	Case Pack	Weight lb (kg)
	110-120 AC	220-240 AC	12 DC							
66631E	•		•		•		•	≥450 (15.9CFM)	6	13.0 (5.9)
66632		•	•		•		•	≥450 (15.9CFM)	6	13.1 (6.0)
66626 / E			•		•		•	≥600 (21.2CFM)	6	8.7 (4.0)
66619E	•						•	≥600 (21.2CFM)	6	8.8 (4.0)
66620		•					•	≥600 (21.2CFM)	6	8.6 (3.9)
66621E	•		•		•		•	≥600 (21.2CFM)	4	10.8 (4.9)
66622		•	•		•		•	≥600 (21.2CFM)	4	10.8 (4.9)
66623E	•					•	•	≥1100 (38.9CFM)	4	11.1 (5.1)
66624		•				•	•	≥1100 (38.9CFM)	4	11.1 (5.1)
68608E	•		•		•		•	≥400 (14.1CFM)	4	30.3 (13.8)
68609		•	•		•		•	≥400 (14.1CFM)	4	30.3 (13.8)
68638 / E				6 x C	•		•	≥380 (13.4CFM)	6	6.4 (2.9)



**64121** NEW**DURA-BEAM® BASIC**

			Approximate Inflated Size	Built-in Pump
	64121E	Twin	39" x 75" x 16½" 99cm x 1.91m x 42cm	110 - 120V 220 - 240V
	64122	Queen	60" x 80" x 16½" 1.52m x 2.03m x 42cm	110 - 120V 220 - 240V

P. 14-15

**64131** NEW**DURA-BEAM® BASIC**

			Approximate Inflated Size	Built-in Pump
	64131E	Twin	39" x 75" x 16½" 99cm x 1.91m x 42cm	110 - 120V 220 - 240V
	64132	Queen	60" x 80" x 16½" 1.52m x 2.03m x 42cm	110 - 120V 220 - 240V

P. 16-17

**64139** NEW**DURA-BEAM® BASIC**

			Approximate Inflated Size	Built-in Pump
	64139E	Queen	60" x 80" x 20" 1.52m x 2.03m x 51cm	110 - 120V 220 - 240V
	64140	Queen	60" x 80" x 20" 1.52m x 2.03m x 51cm	110 - 120V 220 - 240V

P. 18-19

**64769** NEW**PREMAIRE®**

			Approximate Inflated Size	Built-in Pump
	64769E	Queen	60" x 80" x 18" 1.52m x 2.03m x 46cm	110 - 120V 220 - 240V
	64770	Queen	60" x 80" x 18" 1.52m x 2.03m x 46cm	110 - 120V 220 - 240V

P. 36-37

**64780**

			Approximate Inflated Size	Hand Pump
	64780 / E	Cot Size	30" x 75" x 5" 76cm x 1.91m x 13cm	68612

P. 49

**64791**

			Approximate Inflated Size
	64791 / E	Twin	39" x 75" x 8" 99cm x 1.91m x 20cm

P. 48

**64411****DURA-BEAM® PLUS**

			Approximate Inflated Size	Built-in Pump
	64411E	Twin	39" x 75" x 18" 99cm x 1.91m x 46cm	110 - 120V 220 - 240V
	64412	Queen	60" x 80" x 18" 1.52m x 2.03m x 46cm	110 - 120V 220 - 240V

P. 20-21

**64417****DURA-BEAM® PLUS**

			Approximate Inflated Size	Built-in Pump
	64417E	Queen	60" x 80" x 22" 1.52m x 2.03m x 56cm	110 - 120V 220 - 240V
	64418	Queen	60" x 80" x 22" 1.52m x 2.03m x 56cm	110 - 120V 220 - 240V

P. 20-21

**64443** NEW**DURA-BEAM® PLUS**

			Approximate Inflated Size	Built-in Pump
	64443E	Twin	39" x 75" x 20" 99cm x 1.91m x 51cm	110 - 120V 220 - 240V
	64444	Twin	39" x 75" x 20" 99cm x 1.91m x 51cm	110 - 120V 220 - 240V

P. 24-25

**66767**

			Approximate Inflated Size	Built-in Pump
	66767 / E	Twin	39" x 75" x 9" 99cm x 1.91m x 23cm	110 - 120V 220 - 240V
	66775E	Twin	39" x 75" x 9" 99cm x 1.91m x 23cm	110 - 120V 220 - 240V
	66779	Twin	39" x 75" x 9" 99cm x 1.91m x 23cm	110 - 120V 220 - 240V

P. 44-45

**66801**

			Approximate Inflated Size
	66801NP / EP	Cot Size	34½" x 62" x 7" 88cm x 1.57m x 18cm

P. 66

**66810**

			Approximate Inflated Size	Hand Pump
	66810NP / EP	Cot Size	42" x 66" x 10" 1.07m x 1.68m x 25cm	68612

P. 67

**64455****DURA-BEAM® PLUS**

			Approximate Inflated Size	Built-in Pump
	64455E	Twin	39" x 75" x 18" 99cm x 1.91m x 46cm	110 - 120V 220 - 240V
	64456	Queen	60" x 80" x 18" 1.52m x 2.03m x 46cm	110 - 120V 220 - 240V

P. 22-23

**64459****DURA-BEAM® PLUS**

			Approximate Inflated Size	Built-in Pump
	64459E	Queen	60" x 90" x 31" 1.52m x 2.29m x 79cm	110 - 120V 220 - 240V
	64460	Queen	60" x 90" x 31" 1.52m x 2.29m x 79cm	110 - 120V 220 - 240V

P. 30-31

**64461****DURA-BEAM® PLUS**

			Approximate Inflated Size	Built-in Pump
	64461E	Twin	39" x 75" x 20" 99cm x 1.91m x 51cm	110 - 120V 220 - 240V
	64462	Twin	39" x 75" x 20" 99cm x 1.91m x 51cm	110 - 120V 220 - 240V

P. 26-27

**66950**

			Approximate Inflated Size
	66950 / E	Cot Size	30" x 75" x 8¾" 76cm x 1.91m x 22cm
	66927 / E	Twin	39" x 75" x 8¾" 99cm x 1.91m x 22cm
	66928 / E	Full	54" x 75" x 8¾" 1.37m x 1.91m x 22cm

P. 39

**66967**

			Approximate Inflated Size
	66967 / E	Twin	39" x 75" x 8¾" 99cm x 1.91m x 22cm
	66968 / E	Full	54" x 75" x 8¾" 1.37m x 1.91m x 22cm
	66969 / E	Queen	60" x 80" x 8¾" 1.52m x 2.03m x 22cm

P. 40-41

**67765****DURA-BEAM® PLUS**

			Approximate Inflated Size	Built-in Pump
	67765E	Twin	39" x 75" x 13" 99cm x 1.91m x 33cm	110 - 120V 220 - 240V
	67767E	Full	54" x 75" x 13" 1.37m x 1.91m x 33cm	110 - 120V 220 - 240V
	67768E	Queen	60" x 80" x 13" 1.52m x 2.03m x 33cm	110 - 120V 220 - 240V

P. 20-21

**64467****DURA-BEAM® PLUS**

			Approximate Inflated Size	Built-in Pump
	64467E	Queen	60" x 80" x 20" 1.52m x 2.03m x 51cm	110 - 120V 220 - 240V
	64468	Queen	60" x 80" x 20" 1.52m x 2.03m x 51cm	110 - 120V 220 - 240V

P. 28-29

**64481** NEW**PREMAIRE®**

			Approximate Inflated Size	Built-in Pump
	64481E	Twin	39" x 75" x 18" 99cm x 1.91m x 46cm	110 - 120V 220 - 240V
	64482	Twin	39" x 75" x 18" 99cm x 1.91m x 46cm	110 - 120V 220 - 240V

P. 34-35

**64707** NEW**DURA-BEAM® BASIC**

			Approximate Inflated Size
	64707 / E	Twin	39" x 75" x 10" 99cm x 1.91m x 25cm
	64708 / E	Full	54" x 75" x 10" 1.37m x 1.91m x 25cm
	64709 / E	Queen	60" x 80" x 10" 1.52m x 2.03m x 25cm

P. 12-13

**68708**

			Approximate Inflated Size
	68708 / E	Cot Size	30" x 72" x 4" 76cm x 1.83m x 10cm

P. 47

**68797**

			Approximate Inflated Size
	68797 / E	Cot Size	26½" x 72½" x 6¾" 67cm x 1.84m x 17cm
	68798 / E	Twin	28½" x 74½" x 8" 72cm x 1.89m x 20cm
	68799 / E	Queen	50" x 76" x 9½" 1.27m x 1.93m x 24cm

P. 46

**68950**

			Approximate Inflated Size	Hand Pump
	68950 / E	Cot Size	30" x 75" x 8¾" 76cm x 1.91m x 22cm	—
	68757 / E	Twin	39" x 75" x 8¾" 99cm x 1.91m x 22cm	—
	68758 / E	Full	54" x 75" x 8¾" 1.37m x 1.91m x 22cm	—
	68759 / E	Queen	60" x 80" x 8¾" 1.52m x 2.03m x 22cm	68612
	68765 / E	King	72" x 80" x 8¾" 1.83m x 2.03m x 22cm	—

P. 42-43