

INTEX®

2024 Out of Catalog Selection

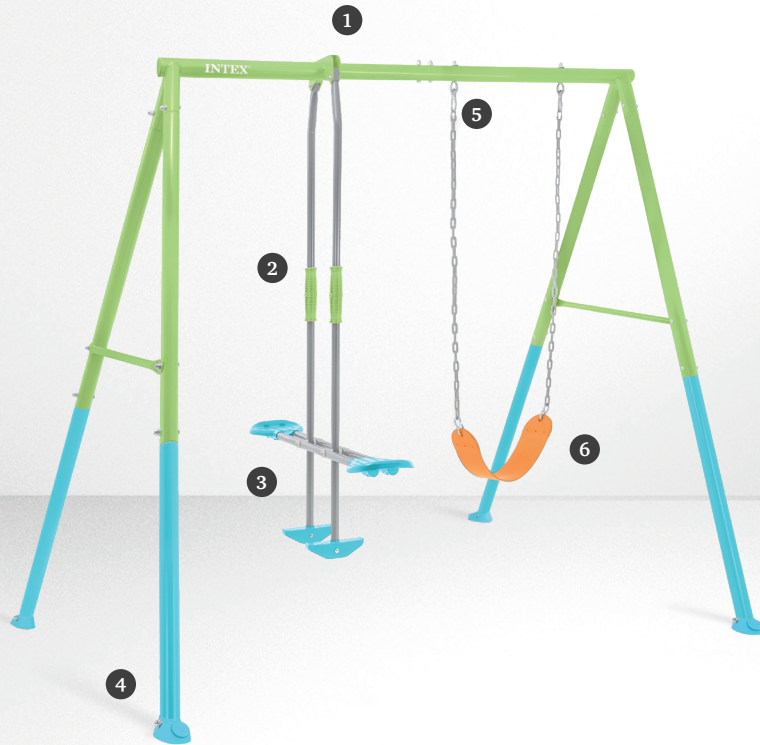

SWING SET

44120 / E TWO FEATURE SWING SET

- 8'3" L x 8'4" W x 6'11" H (2.51m x 2.54 x 2.11m)
- One adjustable swing
- Fun glider swing
- Easy-to-install foot pads with anchor stakes for stability
1 ea, 69.7 lb (31.7 kg)

AGE/ 3-10

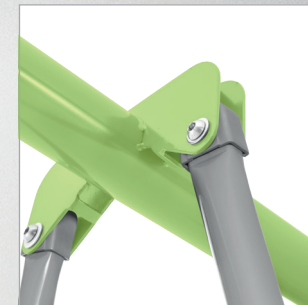

1 Precision welded glider bracket

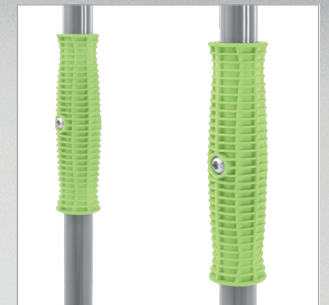

2 Comfortable ergonomic grips



3 Glider with footrests for extra stability

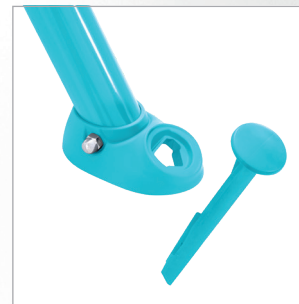

4 Precision-engineered anchor system

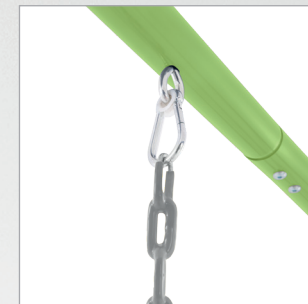

5 Adjustable chain height



6 Flexible seat with plastisol-coated swing chains

PLEASE CONTACT SALES REP FOR MORE INFORMATION

INTEX®

2024 Out of Catalog Selection



SWING SET

44122 / E TWO FEATURE SWING SET

- 8'3" L x 8'4" W x 6'11" H (2.51m x 2.54 x 2.11m)
- One adjustable swing
- Fun glider swing
- Easy-to-install foot pads with anchor stakes for stability
1 ea, 69.7 lb (31.7 kg)

AGE/ 3-10



1 Precision welded glider bracket



2 Comfortable ergonomic grips



3 Glider with footrests for extra stability



4 Precision-engineered anchor system

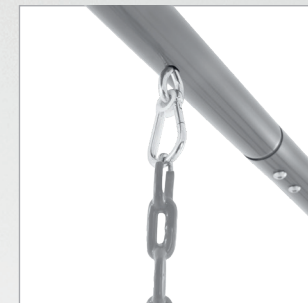

5 Adjustable chain height



6 Flexible seat with plastisol-coated swing chains

PLEASE CONTACT SALES REP FOR MORE INFORMATION

INTEX®

2024 Out of Catalog Selection

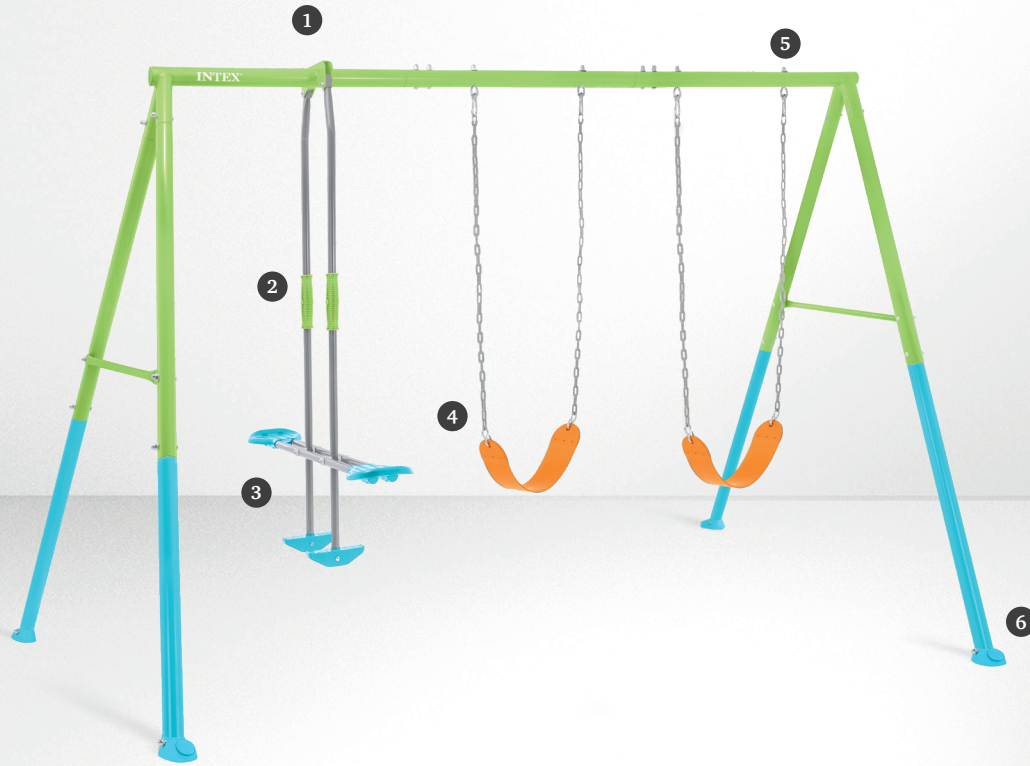

SWING SET

44121 / E THREE FEATURE SWING SET

- 11'3" L x 8'4" W x 6'11" H (3.43m x 2.54m x 2.11m)
- Two adjustable swings
- Fun glider swing
- Easy-to-install foot pads with anchor stakes for stability
1 ea, 81.4 lb (37.0 kg)

AGE/ 3-10



1 Precision welded glider bracket



2 Comfortable ergonomic grips



3 Glider with footrests for extra stability



4 Flexible seat with plastisol-coated swing chains

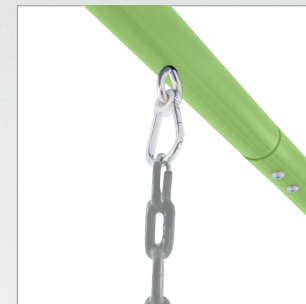

5 Adjustable chain height

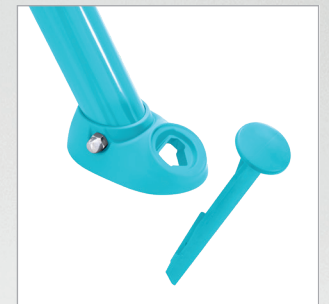

6 Precision-engineered anchor system

PLEASE CONTACT SALES REP FOR MORE INFORMATION

INTEX®

2024 Out of Catalog Selection



SWING SET

44123 / E THREE FEATURE SWING SET

- 11'3" L x 8'4" W x 6'11" H (3.43m x 2.54m x 2.11m)
- Two adjustable swings
- Fun glider swing
- Easy-to-install foot pads with anchor stakes for stability
1 ea, 81.4 lb (37.0 kg)

AGE/ 3-10



1 Precision welded glider bracket



2 Comfortable ergonomic grips



3 Glider with footrests for extra stability



4 Flexible seat with plastisol-coated swing chains

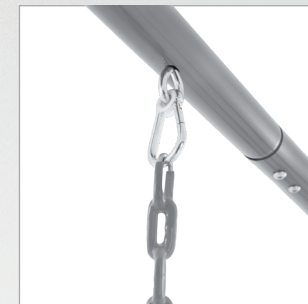

5 Adjustable chain height



6 Precision-engineered anchor system

PLEASE CONTACT SALES REP FOR MORE INFORMATION

INTEX®

2024 Out of Catalog Selection

SWING SET



44130 / E FOUR FEATURE SWING SET

- 15'4" L x 8'4" W x 6'11" H (4.67m x 2.54m x 2.11m)
- Two adjustable swings
- Trapeze bar with gym rings
- Fun glider swing
- Easy-to-install foot pads with anchor stakes for stability
1 ea, 107.7 lb (49.0 kg)

AGE/ 3-10

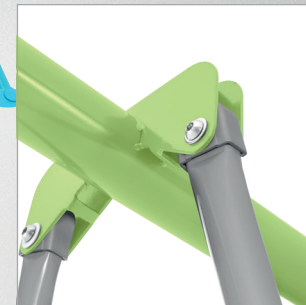

1 Precision welded glider bracket



2 Comfortable ergonomic grips



3 Glider with footrests for extra stability



4 Flexible seat with plastisol-coated swing chains

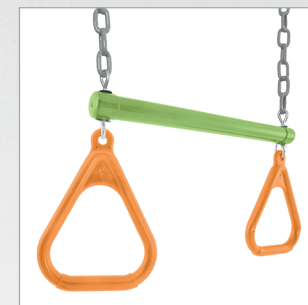

5 Trapeze bar with gym rings

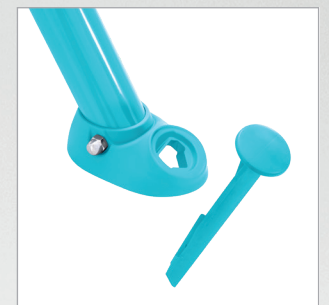

6 Precision-engineered anchor system

PLEASE CONTACT SALES REP FOR MORE INFORMATION

INTEX®

2024 Out of Catalog Selection

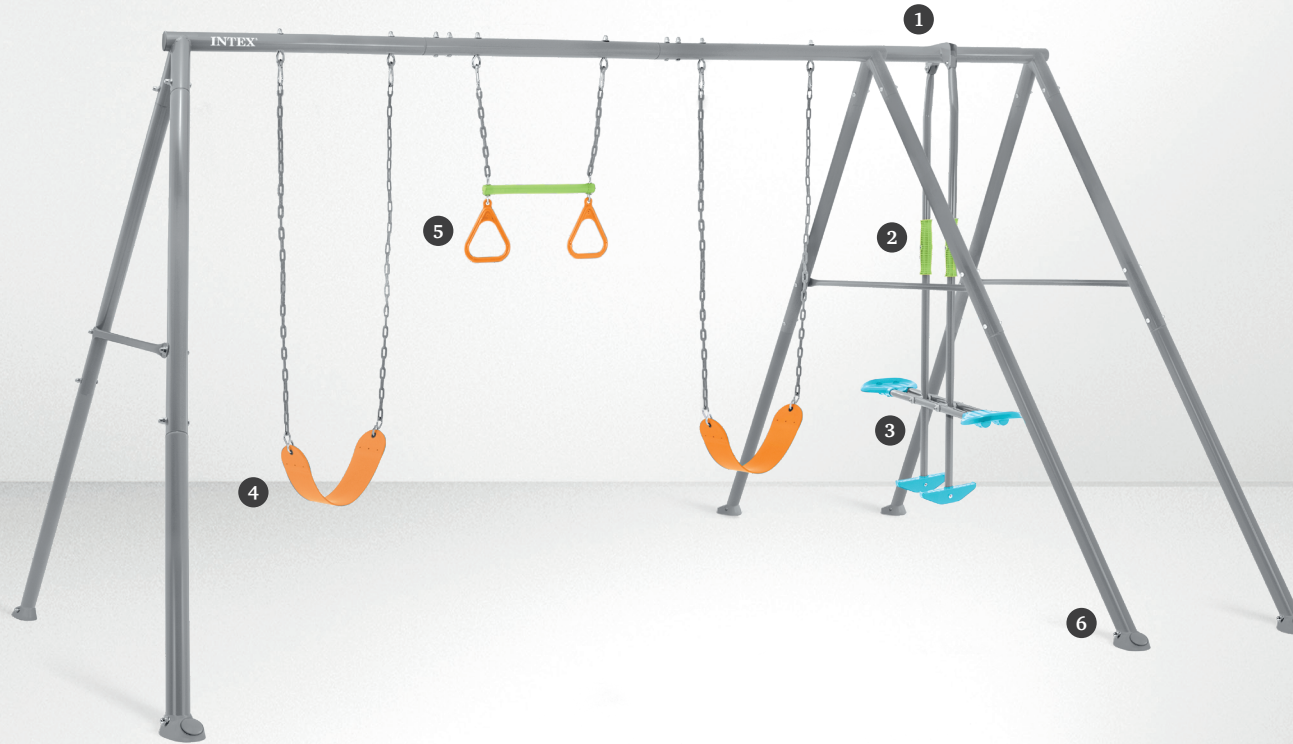

SWING SET

44131 / E FOUR FEATURE SWING SET

- 15'4" L x 8'4" W x 6'11" H (4.67m x 2.54m x 2.11m)
- Two adjustable swings
- Trapeze bar with gym rings
- Fun glider swing
- Easy-to-install foot pads with anchor stakes
1 ea, 107.7 lb (49.0 kg)

AGE/ 3-10

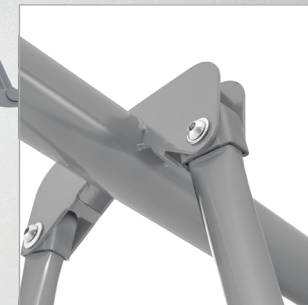

1 Precision welded glider bracket



2 Comfortable ergonomic grips



3 Glider with footrests for extra stability



4 Flexible seat with plastisol-coated swing chains

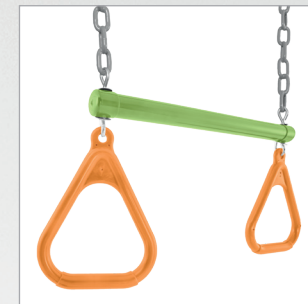

5 Trapeze bar with gym rings



6 Precision-engineered anchor system

PLEASE CONTACT SALES REP FOR MORE INFORMATION

INTEX®

2024 Out of Catalog Selection

NEW



SWING SET

44111 / E

ONE FEATURE SAUCER SWING SET

- 6'8" L x 8'4" W x 6'11" H (2.03m x 2.54m x 2.11m)
- 40" (102cm) octagonal saucer swing
- Saucer holds up to 3 kids
- Saucer swing capacity: 330 lb (150 kg)
- Heavy-duty A-frame design
- 1 ea, 62.9 lb (28.6 kg)

AGE/ 3-10

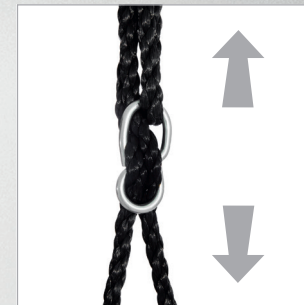

1 Adjustable length



2 Durable foam padded steel construction

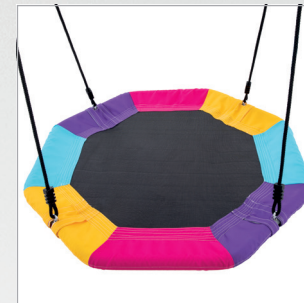

3 Weather resistant 900D Oxford fabric

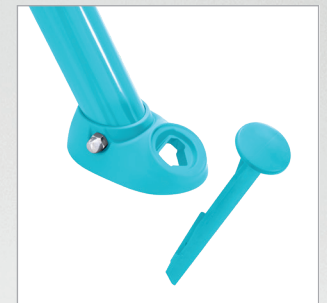

4 Precision-engineered anchor system

PLEASE CONTACT SALES REP FOR MORE INFORMATION

INTEX®

2024 Out of Catalog Selection

NEW



SWING SET

44112 / E

ONE FEATURE SAUCER SWING SET

- 6'8" L x 8'4" W x 6'11" H (2.03m x 2.54m x 2.11m)
- 40" (102cm) octagonal saucer swing
- Saucer holds up to 3 kids
- Saucer swing capacity: 330 lb (150 kg)
- Heavy-duty A-frame design
- 1 ea, 62.9 lb (28.6 kg)

AGE/ 3-10

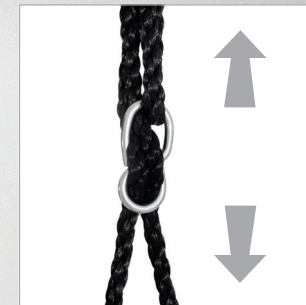

1 Adjustable length



2 Durable foam padded steel construction

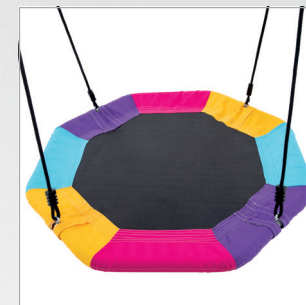

3 Weather resistant 900D Oxford fabric



4 Precision-engineered anchor system

PLEASE CONTACT SALES REP FOR MORE INFORMATION

INTEX®

2024 Out of Catalog Selection

NEW

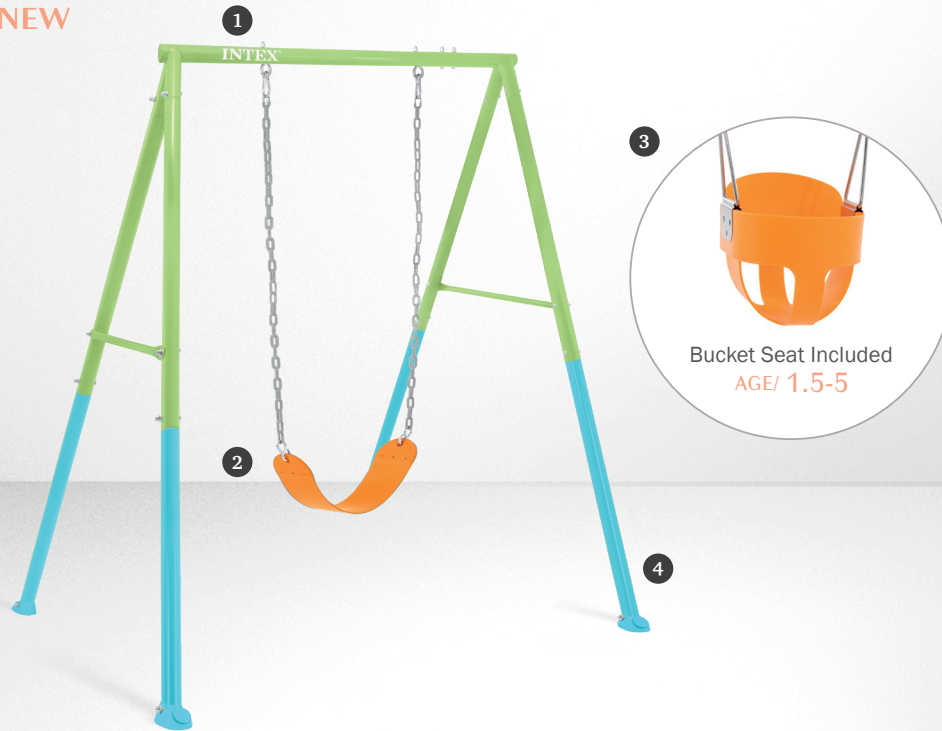

SWING SET

44113 / E TWO-IN-ONE SWING SET

- 5'11" L x 8'4" W x 6'11" H (1.80m x 2.54m x 2.11m)
 - One chain swing
 - Includes one interchangeable toddler bucket swing seat
 - Heavy-duty A-frame design
- 1 ea, 59.1 lb (26.9 kg)

AGE/ 3-10

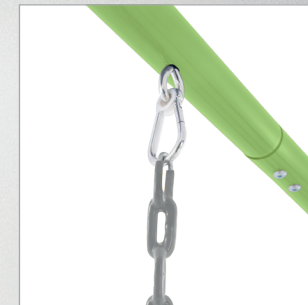

1 Adjustable chain height



2 Flexible seat with plastisol-coated swing chains



3 High back bucket seat for better support

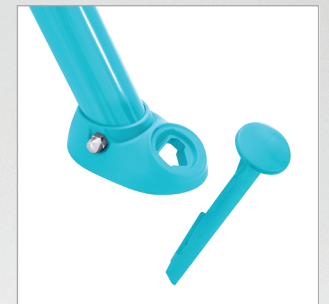

4 Precision-engineered anchor system

PLEASE CONTACT SALES REP FOR MORE INFORMATION

INTEX®

2024 Out of Catalog Selection

NEW

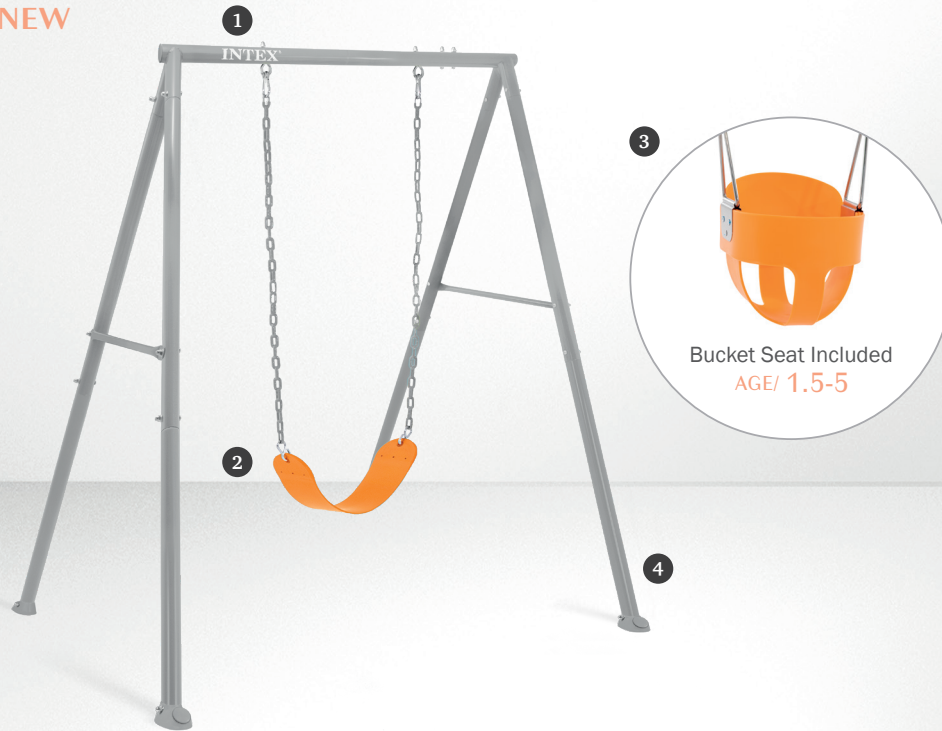

SWING SET

44114 / E TWO-IN-ONE SWING SET

- 5'11" L x 8'4" W x 6'11" H (1.80m x 2.54m x 2.11m)
- One chain swing
- Includes one interchangeable toddler bucket swing seat
- Heavy-duty A-frame design
- 1 ea, 59.1 lb (26.9 kg)

AGE/ 3-10

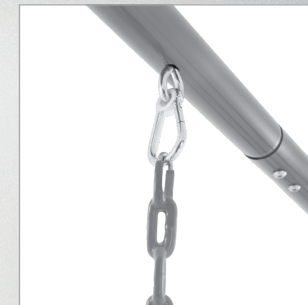

1 Adjustable chain height



2 Flexible seat with plastisol-coated swing chains

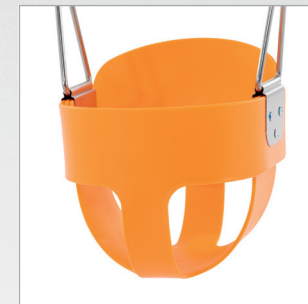

3 High back bucket seat for better support



4 Precision-engineered anchor system

PLEASE CONTACT SALES REP FOR MORE INFORMATION

INTEX®

2024 Out of Catalog Selection

NEW



SWING SET

44125 / E TWO FEATURE SWING SET

- 8'9" L x 8'4" W x 6'11" H (2.67m x 2.54m x 2.11m)
- One chain swing
- One 32" (81cm) octagonal saucer swing
- Saucer swing capacity: 220 lb (100 kg)
- For up to 3 kids
- Heavy-duty A-frame design
- 1 ea, 65.8 lb (29.9 kg)

AGE/ 3-10

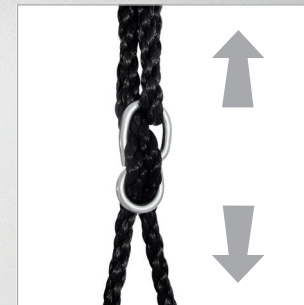

1 Adjustable length



2 Durable foam padded steel construction



3 Weather resistant 900D Oxford fabric



4 Adjustable chain height



5 Flexible seat with plastisol-coated swing chains

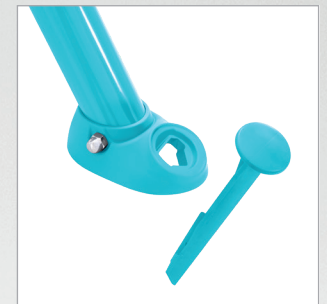

6 Precision-engineered anchor system

PLEASE CONTACT SALES REP FOR MORE INFORMATION

INTEX®

2024 Out of Catalog Selection

NEW



SWING SET

44126 / E TWO FEATURE SWING SET

- 8'9" L x 8'4" W x 6'11" H (2.67m x 2.54m x 2.11m)
- One chain swing
- One 32" (81cm) octagonal saucer swing
- Saucer swing capacity: 220 lb (100 kg)
- For up to 3 kids
- Heavy-duty A-frame design
- 1 ea, 65.8 lb (29.9 kg)

AGE/ 3-10



3 Weather resistant 900D Oxford fabric

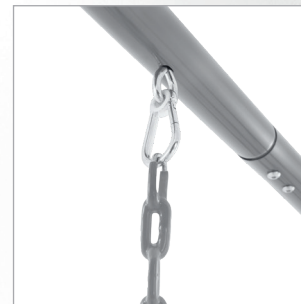

4 Adjustable chain height



5 Flexible seat with plastisol-coated swing chains



6 Precision-engineered anchor system

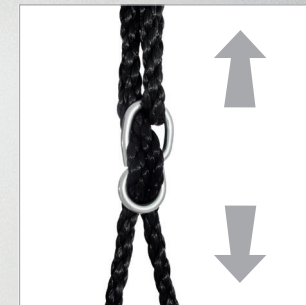

1 Adjustable length



2 Durable foam padded steel construction

PLEASE CONTACT SALES REP FOR MORE INFORMATION

INTEX®

2024 Out of Catalog Selection

NEW



SWING SET

44133 / E THREE FEATURE SWING SET

- 11'10" L x 8'4" W x 6'11" H (3.61m x 2.54m x 2.11m)
- Two chain swings
- One 32" (81cm) octagonal saucer swing
- Saucer swing capacity: 220 lb (100 kg)
- For up to 4 kids
- Heavy-duty A-frame design

AGE/ 3-10



3 Weather resistant 900D Oxford fabric

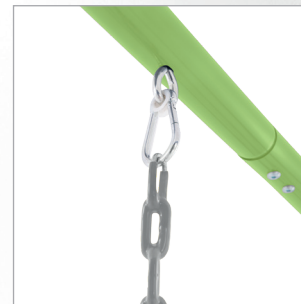

4 Adjustable chain height



5 Flexible seat with plastisol-coated swing chains

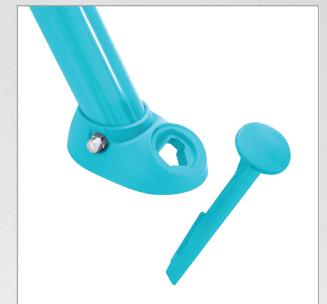

6 Precision-engineered anchor system

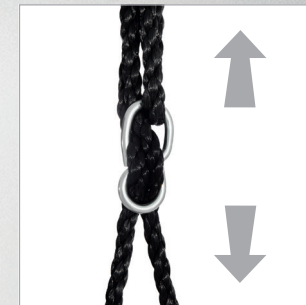

1 Adjustable length



2 Durable foam padded steel construction

PLEASE CONTACT SALES REP FOR MORE INFORMATION

INTEX®

2024 Out of Catalog Selection

NEW



SWING SET

44134 / E THREE FEATURE SWING SET

- 11'10" L x 8'4" W x 6'11" H (3.61m x 2.54m x 2.11m)
- Two chain swings
- One 32" (81cm) octagonal saucer swing
- Saucer swing capacity: 220 lb (100 kg)
- For up to 4 kids
- Heavy-duty A-frame design
- 1 ea, 69.9 lb (31.8 kg)

AGE/ 3-10

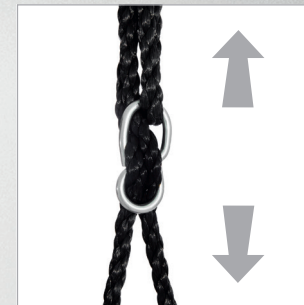

1 Adjustable length



2 Durable foam padded steel construction



3 Weather resistant 900D Oxford fabric

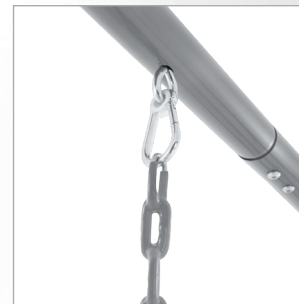

4 Adjustable chain height



5 Flexible seat with plastisol-coated swing chains



6 Precision-engineered anchor system

PLEASE CONTACT SALES REP FOR MORE INFORMATION

INTEX®

2024 Out of Catalog Selection

NEW



SWING SET

44151 / E FIVE FEATURE SWING SET

- 15'6" L x 8'4" W x 6'11" H (4.72m x 2.54m x 2.11m)
- 8'3" L x 2'9" W x 4'10" H (2.51m x 84cm x 1.47m)
- Two chain swings
- One 32" (81cm) octagonal saucer swing
- Saucer swing capacity: 220 lb (100 kg)
- One glider
- One freestanding 8-foot slide
- For up to 7 kids
- Heavy-duty A-frame design
- 2 boxes, 173.8 lb (79.0 kg)

AGE/ 3-10



1 8' (1.07m) freestanding slide

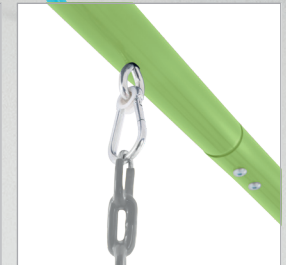

2 Adjustable length/height

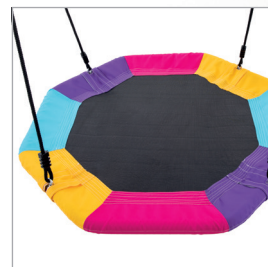

3 Weather resistant 900D Oxford fabric



4 Flexible seat with plastisol-coated swing chains

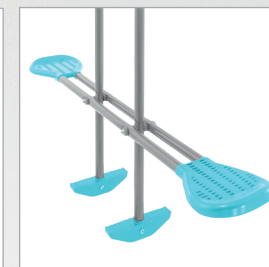

5 Glider with footrests for extra stability

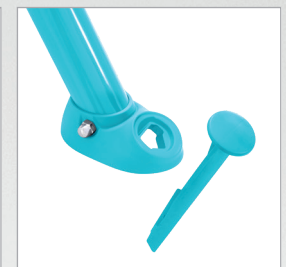

6 Precision-engineered anchor system

PLEASE CONTACT SALES REP FOR MORE INFORMATION

INTEX®

2024 Out of Catalog Selection

NEW



SWING SET

44152 / E FIVE FEATURE SWING SET

- 15'6" L x 8'4" W x 6'11" H (4.72m x 2.54m x 2.11m)
- 8'3" L x 2'9" W x 4'10" H (2.51m x 84cm x 1.47m)
- Two chain swings
- One 32" (81cm) octagonal saucer swing
- Saucer swing capacity: 220 lb (100 kg)
- One glider
- One freestanding 8-foot slide
- For up to 7 kids
- Heavy-duty A-frame design
- 2 boxes, 173.8 lb (79.0 kg)

AGE/ 3-10



1 8' (1.07m) freestanding slide

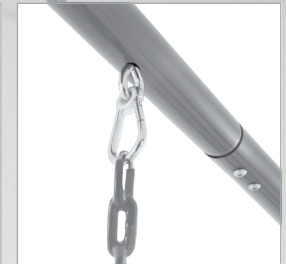

2 Adjustable length/height



3 Weather resistant 900D Oxford fabric



4 Flexible seat with plastisol-coated swing chains

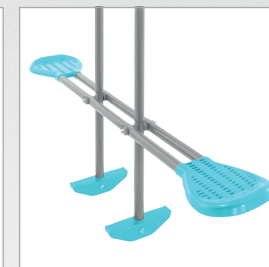

5 Glider with footrests for extra stability



6 Precision-engineered anchor system

PLEASE CONTACT SALES REP FOR MORE INFORMATION

INTEX®

2024 Out of Catalog Selection

NEW

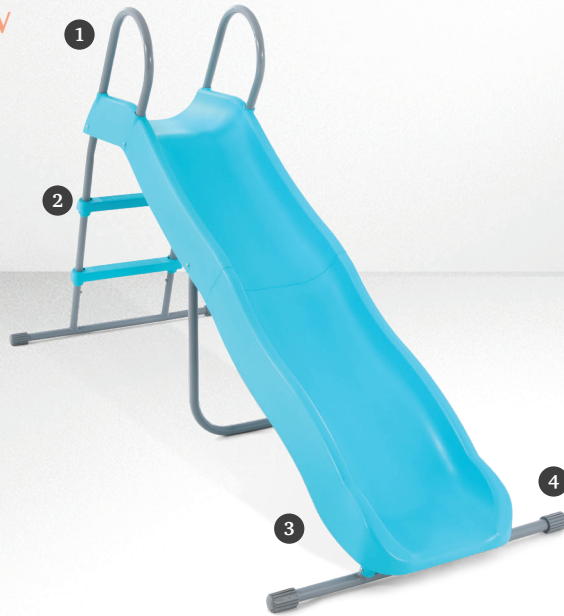

44106 / E SIX-FOOT FREESTANDING SLIDE

- 6'5" L x 2'9" W x 3'11" H
(1.96m x 84cm x 1.19m)
- 2-piece molded plastic construction
- Powder-coated galvanized steel tubes
- 1.1"(2.8cm) steel tube diameter
1 ea, 37.1 lb (16.9 kg)

AGE/ 3-10

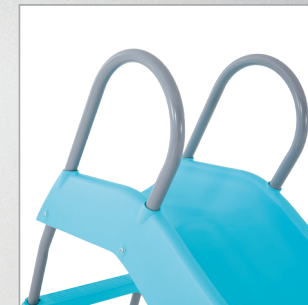

1 Sturdy steel frame



2 Durable steps



3 Smooth curve design

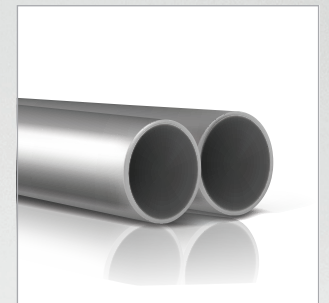

4 1.1"(2.8cm) steel tube diameter

PLEASE CONTACT SALES REP FOR MORE INFORMATION

SWING SET

INTEX®

2024 Out of Catalog Selection

NEW



44107 / E

EIGHT-FOOT FREESTANDING SLIDE

- 8'3" L x 2'9" W x 4'10" H (2.51m x 84cm x 1.47m)
- 3-piece molded plastic construction
- Powder-coated galvanized steel tubes
- 1.1"(2.8cm) steel tube diameter
1 ea, 52.4 lb (23.8 kg)

AGE/ 3-10

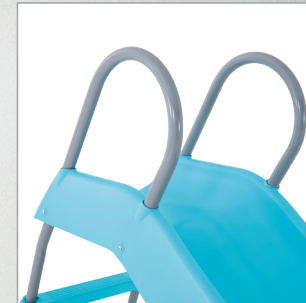

1 Sturdy steel frame



2 Durable steps



3 Smooth curve design



4 1.1"(2.8cm) steel tube diameter

PLEASE CONTACT SALES REP FOR MORE INFORMATION

SWING SET